

Final Report
2015–2023

www.ntnu.edu/move

SFI MOVE

Marine Operations in Virtual Environments



SINTEF



NTNU



Centre for
Research-based
Innovation



Industrial partners:



Research partners:





CONTACT – SFI MOVE

Hans Petter Hildre
Centre Director

Phone: +47 70 16 12 43
Mobile: +47 959 93 659

Magnhild Kopperstad Wolff
Finance & Administrative Coordinator

Phone: +47 70 16 15 60
Mobile: +47 482 25 391

Website:

www.ntnu.edu/move

Postal address:

SFI MOVE

NTNU in Ålesund, Department of Ocean Operations
and Civil Engineering
Postbox 1517
NO-6025 Ålesund, Norway

Office location:

NTNU in Ålesund

Larsgaardsveien 2
Ålesund, Norway

Photos:
Magnhild Kopperstad Wolff
Børge Sandnes
Eli Anne Tvergrov
OSC (animated photos)
Colourbox
Adobe Stock

Layout:
NTNU Grafisk Senter

ISBN 978-82-94056-01-9 (PDF)

Contents

Foreword by Centre Director	4
Foreword by Head of Host Institution	6
Summary	8
Sammendrag	10
Vision and mission	12
Basic facts about the centre	14
Financing through the life of the centre	18
Research	20
International cooperation	38
Training of researchers	40
Dissemination of knowledge	42
Effects of centre	46
Future prospects	48
Conclusions	50
Appendix 1 – Statement of accounts for the complete period of centre financing	52
Appendix 2 – List of Post-docs, Candidates for PhD and MSc degrees	54
Appendix 3 – List of Publications	60

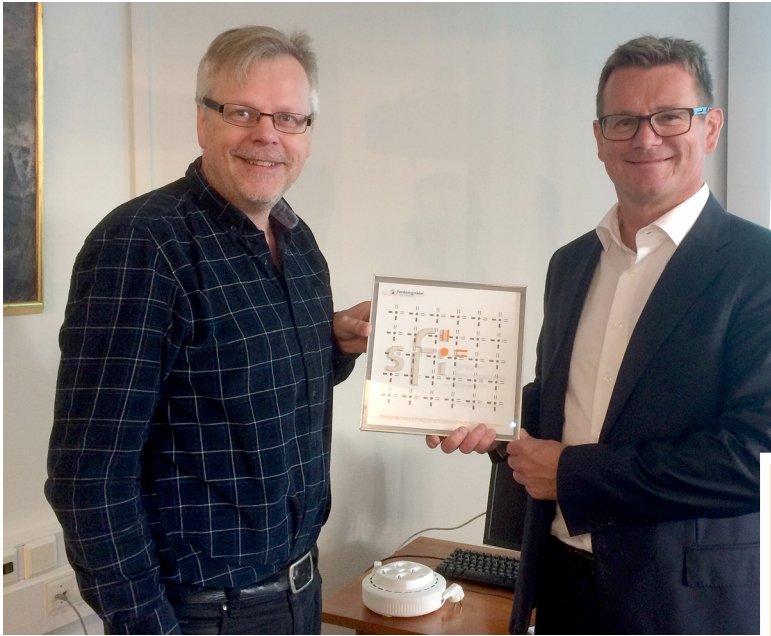

- 10.00 Del 1 Generell
- Mal strategisk
- Organisering
- Planer (Innova
- Rekruttering
- Faglig aktivitet
- Samarbeid og i
- Internasjonalt s
- Budsjett og øko
- Fra maritime op
- Infrastruktur
- Kommunikasjon
- Lunch
- Vi rusler en tur i
- Tilbakemeldinge
- Denne tar vi son



Foreword
by Centre Director



The objective of SFI MOVE was to contribute to commercially solid and cost-effective marine operations, helping to position the Norwegian maritime industry in the market for such operations worldwide. Norway has a long coastline and a continental shelf that is six times larger than the mainland, constituting a third of the European continental shelf. Norway has a strong position in ocean industries such as oil and gas, fishing, fish farming and a growing offshore wind industry. Demanding marine operations are a common core activity in all these segments. 70 % of Norwegian exports are from ocean-based industries, and marine operation is a core activity.

SFI MOVE was granted resources in 2014 and started the project in the autumn of 2015. The Faculty of Maritime Technology at Aalesund University College was the host. MARINTEK and SINTEF Fisheries and Aquaculture were research partners. Aalesund University College has become part of NTNU, and MARINTEK and SINTEF Fisheries and Aquaculture have become SINTEF Ocean. We were very pleased about the restructuring of the research partners in two strong organizations. SFI MOVE has been an instrument in building a unified understanding of marine operations. 20 companies have been involved in research activities in SFI MOVE.

The oil and gas industry and related maritime activity had 10 years of vigorous growth until 2015. Then the global economy faced one of the largest oil-price shocks in modern history. The 70 percent price drop and corresponding financial crisis generated shock waves in the maritime industry. Most oil rigs became inactive and 850 offshore vessels were laid up. The crisis had a dramatic impact on the suppliers and the maritime clusters.

Some partners closed and new partners joined SFI MOVE. Despite the tough economic situation, the industry is recovering, and we can see increased activity and optimism. In 2021–2023, driven by higher energy prices, supply disruptions, and sanctions, the petroleum sector had a growing significance on Norwegian GDP and government cashflow compared to previous years.

In this period, SFI MOVE tried to find a balance between activities that could enhance competitive strength in the short-term and long-term as well as between industrial innovation and scientific merits. I would particularly like to express my gratitude to the industrial partners contributing to SFI MOVE.

In the last period, SFI MOVE was working with the following three projects.

- Operational response in floating offshore wind installations and services
- On-board decision support tool for marine operations
- Remote operations

Results are summarized in this report. Several new projects transferring results from SFI MOVE have been launched.

SFI MOVE has produced 278 publications, 14 PhDs, 9 PD, and 33 scientific reports.

Hans Petter Hildre
Centre Director





Photo: Kristian Raabe Gjosvold

Foreword

by Head of Host Institution



When NTNU merged with the Aalesund University College in 2016, the goal was to strengthen the competence within maritime disciplines and foster closer cooperation with industry. SFI MOVE has been an important instrument for bridging the maritime research communities in Trondheim and Ålesund. Common research projects and joint supervision of PhDs have been instrumental in building a unified understanding and development.

Norway has been a leading nation in ocean research and development. With a continental shelf six times the land area and the second longest coastline in the world, Norway has developed strong research and education institutions. Industries within fisheries, oil and gas services, and fish farming have been established. Now, we can see growing activity within offshore wind. Innovation in demanding marine operations has been the common driver for this development. The SFI Marine Operation in Virtual Environments is therefore at the core of this success factor bringing operations into a digital framework.

Now under construction, the Norwegian Marine Technology Centre will rank among the world's most advanced facilities for research and education in marine engineering. The centre will provide NTNU and SINTEF access to world-class facilities and premises. The centre's main location will be in Trondheim with wet and dry laboratories, workshops, teaching premises, offices, and meeting rooms.

Fjord Laboratory is a laboratory for full-scale experiments and research in the sea. Fjord Laboratory consists of various laboratories in water and on land, and is located in the Trondheimsfjord, around Hitra and Frøya, and in Ålesund.

I would like to take this opportunity to express my gratitude to all the colleagues, researchers, PhDs, postdocs, master's students, partners, and collaborators who have contributed to creating competence, knowledge, and innovations in SFI MOVE. I would also like to emphasize the importance of the partnerships with SINTEF, Olympic Shipping, Ulstein International, Kongsberg Maritime, TechnipFMC, Subsea 7, Equinor, Havila Shipping, Havfram, DNV, Vard, NTNU Ocean Training, OSC and ÅKP. Together with NTNU, you have provided important support in terms of cash and in-kind contributions.

Finally, I would like to express my gratitude to the Research Council of Norway for designating us as a centre for research-based innovation and for providing funding. Their trust in our research has been instrumental in our success, and we are grateful for the support.

Olav Bolland
Dean, Faculty of Engineering

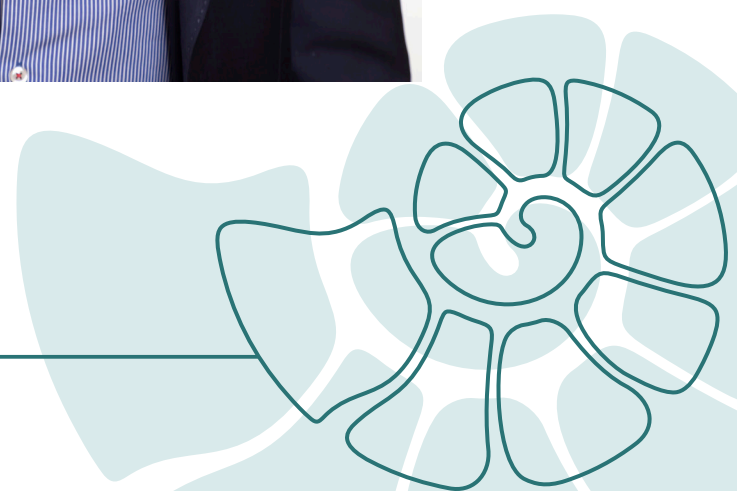

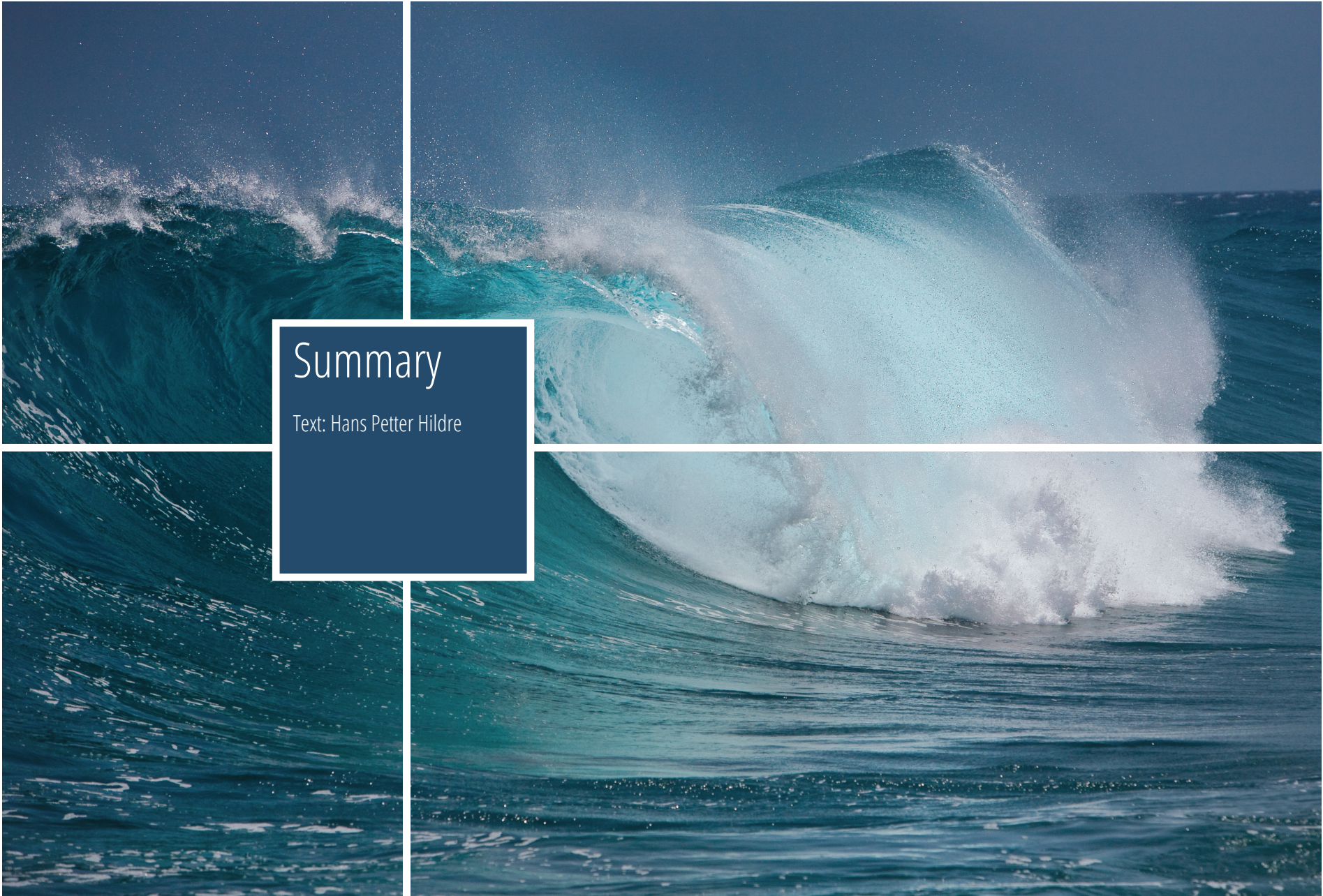
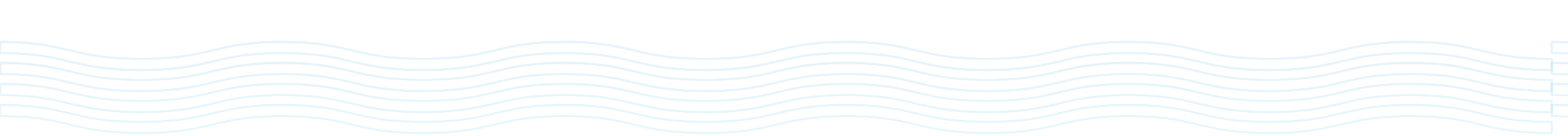

Summary
Text: Hans Petter Hildre

The overall objective of SFI MOVE is to facilitate commercially competitive and cost-effective solutions in marine operations, thus contributing to positioning the Norwegian maritime industry in the global market for such operations. As operations become more extensive, there is a need for more all-year marine operations. The need for all-year operations will significantly impact technology, operational procedures, and costs, and will require very different solutions depending on the operating environment. SFI MOVE contributions are summarized as follows:

Contributions to improved simulation accuracy

In many cases, the limiting sea state depends on the hydrodynamic coefficients used in the analyses. Research has been done to improve the accuracy of coefficients and support project engineers in design and analysis of marine operations on a day-to-day basis. The purpose is of course to reduce Waiting on Weather.

More accurate hydrodynamic coefficients

Hydrodynamic coefficients for subsea structures and structure parts relevant for subsea lifting and installation operations have been developed. Libraries and a user guide have been made.

Vessel shielding effects

Methods for considering shielding effects from an installation vessel on a lifted object have been developed.

Splash zone hydrodynamics

Estimates of hydrodynamic coefficients in the water entry phase of elements of subsea modules have been developed. The focus has been on estimation of slamming load and coefficients as well as damping and added mass coefficients.

Co-simulations

Co-simulation in maritime operations has been explored. Co-simulation is modular by nature and highly flexible, whereby a full system simulation is built from several stand-alone sub-simulators. It leverages specialized toolchains and domain-specific knowledge already in use

by participants and partners. Tools and domain knowledge within hydrodynamics can be combined with tools and methods within hydraulics, control systems and so on.

Contributions to on-board simulations

Marine operations are designed, simulated, and planned long before the operation is carried out. Parameters are assumed for the type of vessel, load condition, wind, waves, lifted objects' behaviour in air and sea, etc. The simulation results show that the operation can be carried out if a given sea state is not exceeded. Therefore, simulations are based on a series of assumptions and uncertainties. Significant safety margins are needed to compensate for these uncertainties.

SFI MOVE has several contributions for how to reduce Waiting on Weather by bringing the analyses close to the operations and defining operations by measured and predicted responses. Using a digital twin technology facilitates go criteria for the operations in terms of vessel or crane response rather than met-ocean parameters, which leads to more precise operational criteria.

On-board decision support system simulation architecture (ODSS)

Today's simulation software must be re-designed to include real-time information from sensors. Researchers at SFI MOVE developed proof-of-concept simulation architecture allowing sensors from the ship or surroundings to be included in the simulation.

Digital twin of marine operations

Digital twin concepts have been tested using the NTNU research vessel R/V Gunnerus. Responses were simulated based on present metocean as well as predicted future situations.

Data driven ship model tuning methodology and methods

Two methods have been developed. First, based on spectral values of measured wave and ship motions on an operating vessel, the parameters of the theoretical ship model are adjusted to match the response of the

theoretical model to the measured response of the operation vessel. Second, a machine learning algorithm is used to compensate for the error in the theoretical ship model. Both methods are tested and verified.

Contributions to remote operations and handover from engineering to operations

Marine operations are increasingly technology based. New technological solutions such as digital twins, cloud computing and machine learning enable faster change and create more complex and dynamic work environments. The driver for such development is reduced costs by having remote support replacing human support on board. Advantages also include increased quality through access to a broader variety of competence and reduced risk through capacities to perform advanced analytics and trade-off scenarios.

Remote operation framework

A remote operations framework can be established by adding a copy of the on-board digital twin to a remote centre. The sensors' signals will be transferred to the remote centre and all responses will be calculated by the digital twin. The idea is to have a single tool covering the process from engineering to handover to on-board to a remote operation centre.

Contributions to response predictions

The aim of this activity is to improve today's methods for the prediction of vessel response for the execution of marine operations. Prediction can broadly be divided into two categories: short-term and long-term prediction. Short-term prediction means predicting the vessel's response a few minutes ahead. This is useful when a critical action of short duration is to be carried out. Long-term prediction (hours and days) is relevant for longer operations where the motion of the vessel must be kept within given limits. In both cases, good response prediction depends on good prediction of waves and other met-ocean disturbances and good response models.

Case studies

Case studies are used as an in-depth examination to explore opportunities within a real-world context. Challenges have been identified and used as an input to new research activities. Cases have been used for both practical and theoretical issues. The cases have also been important to verify new theories and methods. The following areas for cases have been used throughout the project:

- Offshore mining
- Subsea lifting operations
- Installation of offshore wind
- Remote operations

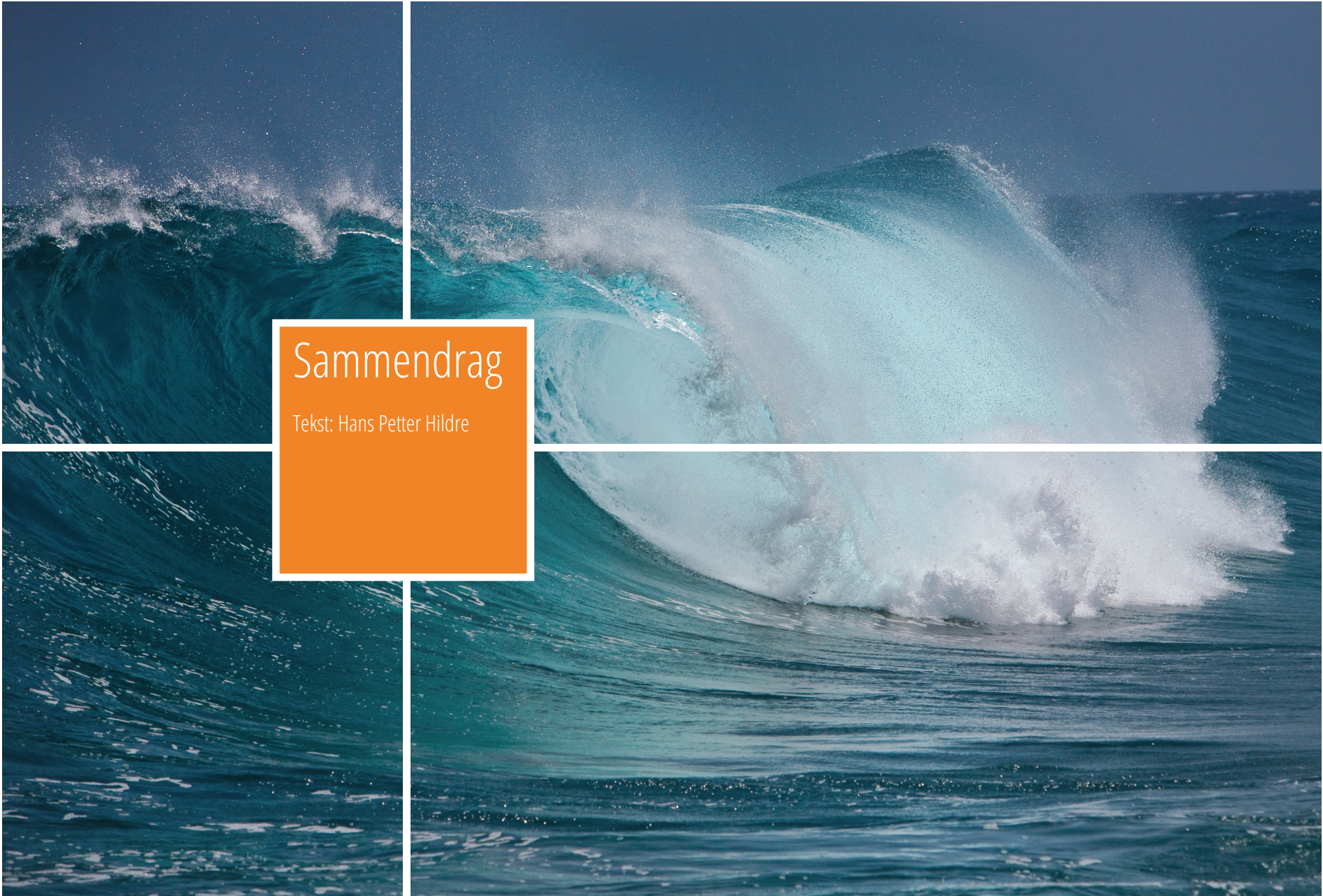
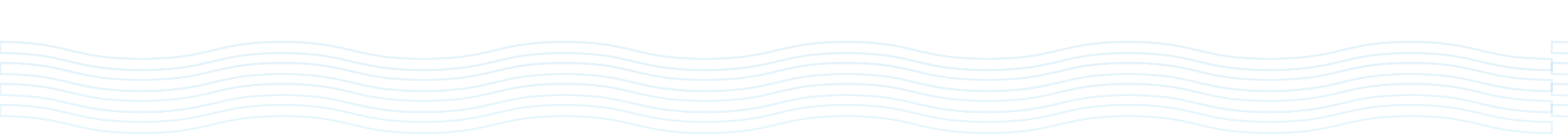

Sammendrag

Tekst: Hans Petter Hildre

Det overordnede målet med SFI MOVE er å legge til rette for konkurransedyktige og kostnadseffektive marine operasjoner, og dermed bidra til å posisjonere den norske maritime industrien i det globale markedet. Ettersom operasjonene blir mer krevende, øker behovet for mer helårs marine operasjoner. Behovet for helårs aktivitet vil ha betydelig innvirkning på teknologi, operasjonelle prosedyrer og kostnader, og vil kreve svært forskjellige løsninger avhengig av sjøtilstand, vind, havstrøm osv. SFI MOVEs bidrag oppsummeres som følger:

Bidrag til forbedret simuleringsnøyaktighet

De hydrodynamiske koeffisientene er sentral i å beregne maksimal sjøtilstand for å kunne gjennomføre en operasjon. Det er gjort forskning for å forbedre nøyaktigheten av koeffisientene og dermed støtte prosjektingeniører i design og analyse av marine operasjoner i det daglige. Formålet er selvfølgelig å redusere ventetid på godt nok vær (WoW).

Mer nøyaktige hydrodynamiske koeffisienter

Hydrodynamiske koeffisienter for undervannsstrukturer og andre konstruksjoner relevant for undervanns løfte- og installasjonsoperasjoner har blitt utviklet. Bibliotek og brukerveiledning er laget.

Effekter av skjerming på le-siden av fartøyet

Metoder for å ivareta effekten av skjerming på le-siden på installasjonsfartøy under løfteoperasjoner har blitt utviklet.

Skvalpesonehydrodynamikk

Estimat av hydrodynamiske koeffisienter i det objekter treffer vannflaten har blitt utviklet. Fokuset har vært på vurdering av koeffisienter for «slambelastning» så vel som koeffisienter for demping og tilleggsmasse.

Co-simuleringer

Co-simuleringer i marine operasjoner har blitt undersøkt og testet. Co-simulering har en modular metodikk hvor en setter opp en systemsimulering basert på å sette sammen flere frittstående del-simuleringer. Co-simulering tillater å bruke modeller fra spesialiserte verktøjkjeder,

gjern domenespesifikke verktøy som allerede er i bruk i fagmiljøene. Verktøy og domenekunnskap innen hydrodynamikk kan kombineres med verktøy og metoder innen hydraulikk, mekanikk, kontrollsystemer osv.

Bidrag til simuleringer ombord i fartøyet

Marine operasjoner blir designet, simulert og planlagt lenge før operasjonen gjennomføres i virkeligheten. Parametere antas for en type fartøy, lasttilstand, vind, bølger, løftede objekters oppførsel i luft og sjø osv. Simuleringsresultatene viser at operasjonen kan gjennomføres hvis en gitt sjøtilstand ikke overskrides. Derfor er simuleringer basert på en rekke antagelser og usikkerheter. Betydelige sikkerhetsmarginer er nødvendige for å kompensere for disse usikkerhetene. SFI MOVE har flere bidrag til hvordan man kan redusere ventetid på været ved å bringe analysene nærmere operasjonene og definere operasjonene ved målte og predikterte responser. Med bruk av digital tvilling-teknologi kan en bruke responskriterier som for eksempel krefter i kranwire eller skipsbevegelser i stedet for parametere for sjøtilstand, noe som fører til mer presise operative kriterier.

Arkitektur for simulering av beslutningsstøttesystemer om bord (ODSS)

Simuleringsprogramvare må utvikles for å inkludere sanntidsinformasjon fra sensorer. Forskere ved SFI MOVE har utviklet en testversjon av simuleringsarkitektur som tillater at sensorer fra skipet eller omgivelsene inkluderes i simuleringen.

Digital tvilling av marine operasjoner

Konsepser innen digitale tvillinger har blitt testet ved bruk av NTNU-forskningsfartøyet R/V Gunnerus. Responser ble simulert basert på nåværende sjøtilstand samt predikterte fremtidige situasjoner.

Metodikk og metoder for tuning av skipsmodeller

To metoder har blitt utviklet. Den første er basert på spektrale verdier av målt bølge- og skipsbevegelser på et operativt fartøy. Parameterne til den teoretiske skips-

modellen justeres for å matche den målte responsen til operasjonsfartøyet. I den andre metoden brukes en maskinlæringsalgoritme for å kompensere for feilen i den teoretiske skipsmodellen. Begge metodene er testet og verifisert.

Bidrag til fjernoperasjoner

Marine operasjoner blir i økende grad teknologibaserte. Nye teknologiske løsninger som digitale tvillinger, skyberegning og maskinlærings muliggjør raskere endring og skaper mer komplekse og dynamiske arbeidsmiljø. Driveren for en slik utvikling er reduserte kostnader ved at deler av personene om bord i fartøyet sitter i et fjernstøttesenter. En kan også oppnå økt kvalitet gjennom tilgang til et bredere spekter av kompetanse og sikrere beslutninger ved å gjennomføre simuleringer av alternative scenarier.

Rammeverk for fjernoperasjoner

Et rammeverk for fjernoperasjoner kan etableres ved å både ha en digital tvilling om bord og i et fjernsenter på land. Signal fra sensorer på skipet vil bli overført til fjernsenteret, og alle responser vil bli beregnet av den digitale tvillingen. Ideen er å ha et simuleringsverktøy som dekker prosessen fra engineering og design av en operasjon til å gi mannskapet ombord i fartøyet innsikt i operasjonen og videre til et fjernoperasjonscenter.

Bidrag til responsprediksjoner

Målet med denne aktiviteten er å forbedre dagens metoder for prediksjon av fartøysrespons for gjennomføring av marine operasjoner. Prediksjon kan grovt deles inn i to kategorier: kortsiktig og langsiktig prediksjon. Kortsiktig prediksjon betyr å forutsi fartøyet respons noen minutter frem i tid. Dette er nyttig når en kritisk handling av kort varighet skal utføres. Langsiktig prediksjon (timer og dager) er relevant for lengre operasjoner der fartøyet bevegelse må holdes innenfor gitte grenser. I begge tilfeller avhenger god responsprediksjon av god prediksjon av bølger og andre metocean forstyrrelser og gode responsmodeller.

Case-studier

Case-studier er brukt til grundige mulighetsstudier innenfor en virkelig kontekst. Utfordringer har blitt identifisert og brukt som inngang til nye forskningsaktiviteter. Casene har blitt brukt både for praktiske og teoretiske utfordringer. Casene har også vært viktige for å verifisere nye teorier og metoder. Følgende områder for casestudier har blitt brukt gjennom hele prosjektet:

- Offshore gruvedrift
- Subsea løfteoperasjoner
- Installasjon av offshore vind
- Fjernoperasjoner

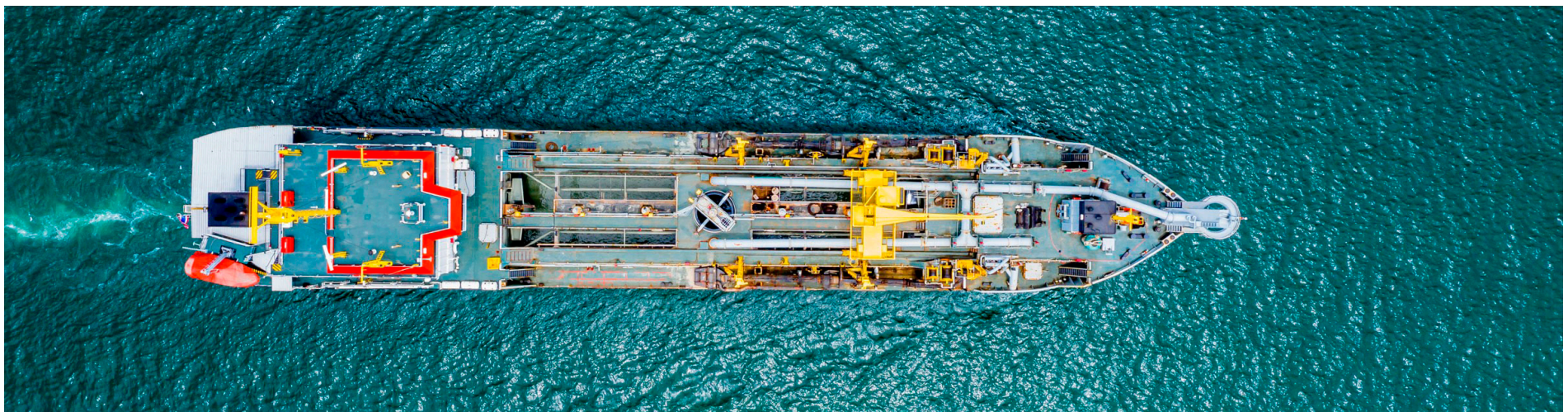
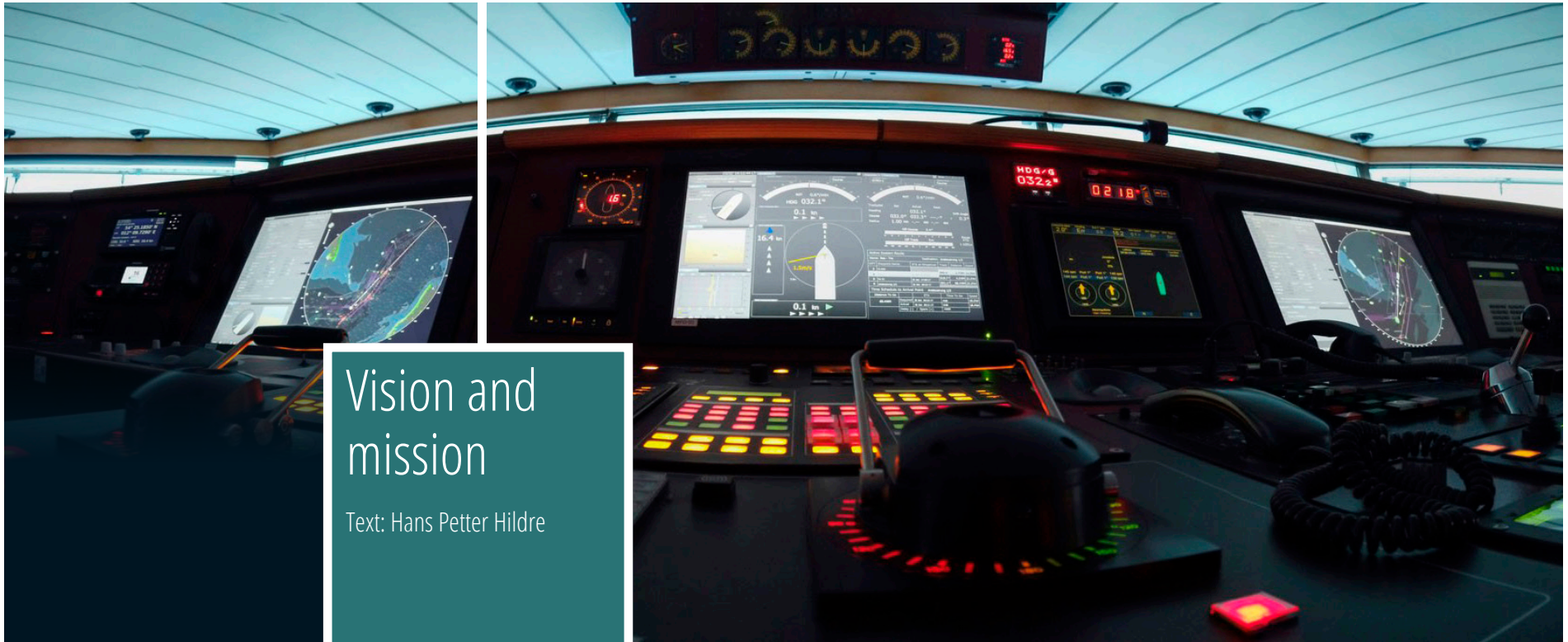

Vision

To establish a world-leading research and innovation centre for demanding marine operations.

Simulation has been used for decades to plan and verify marine operations and to train crew to perform the operations. Next-generation technology has the potential to provide virtual prototyping to pre-test marine operations including human components. On-board and remote support simulation systems consider the real met-ocean situation and the ship's real behaviour will reduce Waiting on Weather and thereby reduce costs. Remote support has the potential to move experts from the ship to the land-based organization.

Cutting-edge interdisciplinary research will provide a bridge between industrial needs, innovation, and research.

Research

Our goal is to take a world-leading position within demanding marine operations.

Innovation

Our goal is to put the industrial partners in front of defining needs and potential for innovation and business.

Education

The research shall lead to theory and new methods for education as well as training of professionals.

Arena

The goal is to establish an arena for research and industrial cooperation within demanding marine operations.

Objectives

The SFI centre shall support the entire value chain for marine operations by developing knowledge, methods, and computer tools for safe and efficient analysis of both the equipment and the operation. The developed methods shall be implemented in simulator environments to pre-test marine operations including the human component.

The SFI centre shall support the innovation process of the marine operation value chain through active involvement by industry, thus improving the competitiveness of Norwegian marine industry. The centre shall:

- Achieve all-year subsea operations installation and service
- Perform safer and more cost-efficient operations
- Support innovation in existing and emerging ocean industries

The idea is to optimize operations, from planning to execution, by a better understanding of the responses. This is a simulation-oriented approach where models are reused throughout the value chain. To fulfil this goal, the following is of vital importance:

- Improved understanding of complex physical phenomena
- Modelling and Virtual Prototyping (simulation)
- Simulation as an industrial standard
- On-board decision support systems
- Online environment monitoring
- Improved crew performance (training and assessment)

Business areas

- Demanding marine offshore operations at deep water, all-year availability, or arctic areas

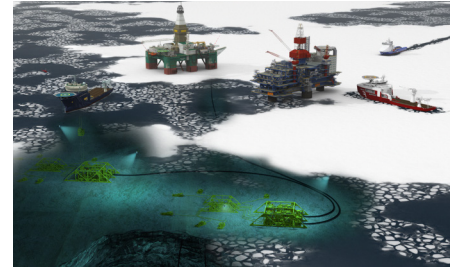

- Installation and maintenance of offshore wind



- Management of marine operations and shipping





Basic facts
about
the centre



From boom to crises in the offshore industry

The oil and gas industry and related maritime activity had 10 years of vigorous growth until 2015. Then the global economy faced one of the largest oil-price shocks in modern history. The 70 percent price drop over that period was one of the three largest declines since World War II, and the most persistent since the supply-driven collapse of 1986. Most oil rigs became inactive and 850 offshore vessels were laid up. The crises had a tremendous impact on the suppliers and the maritime clusters.

The offshore oil and gas industry paid a lot attention to cost reduction during the first years in the project period. We have seen significant restructuring of the offshore support business and efforts reducing costs have been top priority. Despite the tough economic situation, the industry is in recovery, and we can see increased activity and optimism.

Some partners ended their participation and new partners joined SFI MOVE. A significant change in focus was introduced as a part of the mid-way evaluations. We will therefore present basic facts for the first period and second project period separately.

Organization

The centre is organized with a Centre Director and a Centre Board approving research plans and follow-up activities. The day-to-day activities are managed by a Centre Research Leader Team and Centre Management.

A scientific advisory board assures research quality and an industrial advisory board gives advice regarding topics to be focused. The advisory board was very important in the transitions caused by the oil crises.

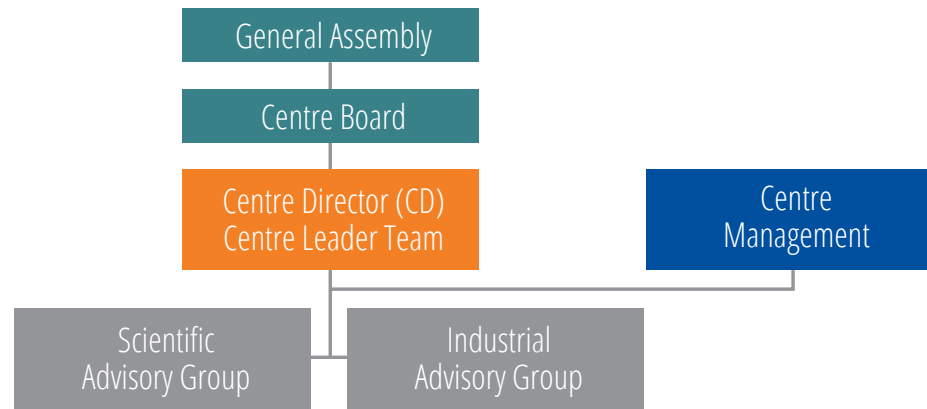

Organization chart.

Main organization in the first period

Centre Management



Hans Petter Hildre, NTNU
Centre Director



Magnhild K. Wolff, NTNU
Centre administration

Centre Research Leader Team



Svein Sævik
NTNU



Henning Borgen
SINTEF Ålesund



Karl Henning Halse
NTNU



Frøy Birte Bjørneseth
NTNU

Research partner(s)

- NTNU
- MARINTEK
- SINTEF Fiskeri og Havbruk

Industry partners

- Farstad Shipping
- Olympic Shipping
- Havila Shipping
- Rolls-Royce Marine
- Ulstein International
- ÅKP/GCE Blue Maritime
- Offshore Simulator Centre, OSC
- Vard
- Cranemaster
- NTNU Ocean Training
- Statoil Petroleum
- EMAS AMC
- Ocean Installer
- Statkraft
- DNV-GL

The Centre Board

- Torleif Sætrevik, Chairman (Statkraft)
- Thore Thuestad (Statoil)
- Tore Ulstein (Ulstein International)
- Guro Løken (EMAS AMC)
- Hans Petter Hildre (NTNU in Ålesund)
- Harald Ellingsen2 (NTNU)
- Halvor Lie (Marintek)

Scientific Advisory Committee

- Odd Magnus Faltinsen, NTNU
- Torgeir Moan, NTNU
- Kazuo Nishimota, University of Sao Paulo (USP)

Main organization in the second period

Centre Management



Hans Petter Hildre, NTNU
Centre Director



Magnhild K. Wolff, NTNU
Centre administration

Centre Research Leader Team



Svein Sævik
NTNU



Egil Giertsen
SINTEF Ocean



Karl Henning Halse
NTNU



Marie Haugli-Sandvik
NTNU

Research partner(s)

- NTNU
- SINTEF Ocean

Industrial partners

- Olympic Shipping
- Havila Shipping
- Kongsberg
- Ulstein International
- OSC
- Vard
- NTNU Ocean Training
- Equinor
- Havfram
- DNV
- Subsea 7
- TechnipFMC

The Centre Board

- Rafael Rossi, Chairman (TechnipFMC)
- Erling Myhre, (Equinor)
- Tore Ulstein (Ulstein International)
- Sverre Torben (Kongsberg, formerly Rolls-Royce Marine)
- Hans Petter Hildre (NTNU)
- Sverre Steen (NTNU)
- Harald Stenersen (Havila Shipping)
- Arne Fredheim (SINTEF Ocean)
- Runar Stave (Olympic)

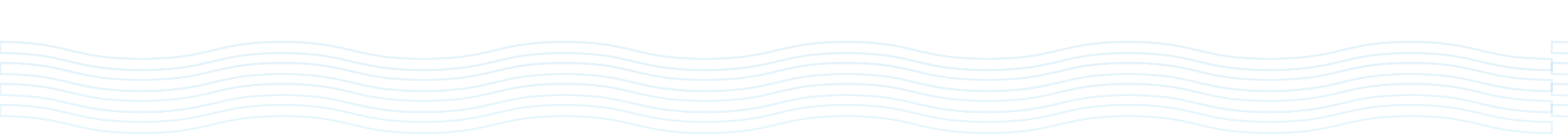

Financing
through the life
of the centre



Summary sheet for the main categories of partners (NOK million)

Contributor	Cash	In-kind	Total
Host	-	16,326	16,326
Research partners	-	28,718	28,718
Companies	27,615	16,028	43,643
Public partners	-	-	-
Research Council of Norway	90,072	-	90,072
Sum	117,687	61,072	178,759

In the table above, the figures for Host consist of the Faculty of Maritime Technology at Aalesund University College in 2015. After Aalesund University College and NTNU merged in 2016, the figures for Host consist of Department of Ocean Operation and Civil Engineering at NTNU in Ålesund.

Distribution of resources (NOK million)

Type of activity NOK million	NOK million
Research projects	155,152
Administration	12,371
Lab/Dissemination	11,236
Total	178,759

Results – Key figures

Summary sheet for the main categories of partners (NOK million)	2015	2016	2017	2018	2019	2020	2021	2022	2023	Total
Scientific publications (peer reviewed)	7	20	23	21	24	22	20	15	10	162
Dissemination measures for users	4	35	45	25	23	10	6	18	5	171
Dissemination measures for the general public	-	-	-	-	-	1	5	4	2	12
PhD degrees completed	-	-	-	-	1	5	3	2	3	14
Master's degrees	2	30	15	16	15	12	6	10	13	119
Number of new/improved methods/models/prototypes finalized	-	-	16	9	-	1	-	1	5	32
Number of new/improved products/processes/services finalised	-	-	3	-	-	1	-	1	-	5
Patents registered	-	-	-	-	-	-	-	-	-	-
New business activity	-	-	-	-	-	-	-	-	-	-

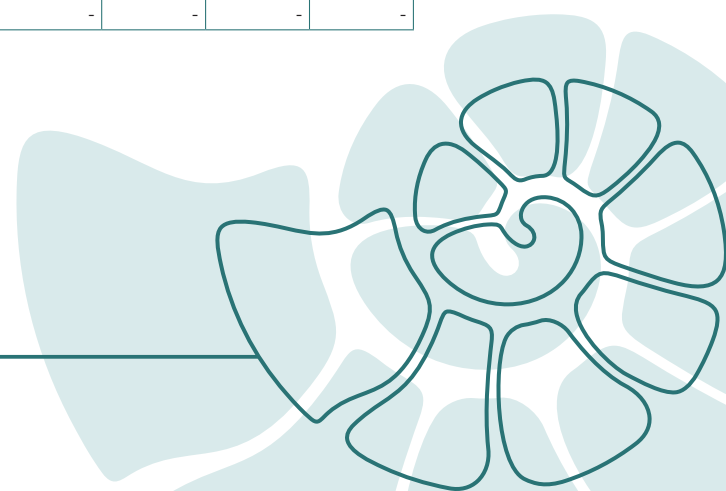



Research

Text:
Hans Petter Hildre
Svein Sævik
Karl Henning Halse
Egil Giertsen
Marie Haugli-Sandvik



Photo: Sunnmørsposten, Steale Wettø

Original research plan and development of research plan

The project portfolio in the beginning of SFI MOVE was:

- Seabed mining
- Virtual prototyping
- Installation and service of offshore wind, bottom-fixed
- Installation and service of offshore wind, floating structures
- All-year subsea operations

The original research plan had a long-term research philosophy. The industry was experiencing high demand and did not express short-term needs. Then the global oil crises hit the industry. The 70 % drop in the oil price had consequences. The crises hit shipowners as well as suppliers and maritime industrial clusters involved in SFI MOVE. Businesses were closed and cost reductions gained focus.

SFI MOVE took this change into consideration to shift focus from long-term goals to a shorter horizon of research. The project portfolio and the content in the projects gradually changed from exploration and solving fundamental problems to low-cost operations. The focus turned to solving industrial problems and creating new tools and methods. The Industrial Advisory Group was heavily involved in this process in 2017 and 2018 and an innovation plan was made. The plan identified marine operations and industrial challenges to be focused on (voice of the user).

The shift, including budgets, was finalized as part of the mid-way evaluation in 2019. Two projects were stopped, two projects were redefined, and a new project was launched.

Seabed mining

The overall goal for this project was to explore technologies to develop seabed mining as a new business area. Seabed mining is a promising area but has not been prioritized by the companies due to restructuring and a strong focus on short-term business opportunities.

For the mining industry, a shift from onshore to offshore operations would offer a large and growing resource potential. Present challenges also creating offshore opportunities include future lack of onshore resources, rare earth material challenges, geopolitical positioning, conflicting societal interests (environmental damage vs business). A large volume of resources is most likely available both inside and outside national waters, but there is very high uncertainty around the value of these resources. In Norwegian waters alone, an NTNU study estimates that a low estimate would be USD 75 bn, with no upper limit. SFI MOVE had a focus on the design of lift systems to allow efficient lifting of minerals from the seabed to the ship. New simulation models were developed, and the research activity was completed in 2019.

Virtual prototyping

The primary objective was to develop an open, standardized framework and architecture for system simulation and virtual prototyping. A key to achieving such functionality is an open framework, standardized interfaces, and generic models to be shared in the industry. The plan was to present methods and demonstrate the cycle from design to virtual prototyping as shown in Figure 1.

The idea was to close the gap between ship design, equipment manufacturers and marine operations. This shift will move simulation from a verification point of view to a design and operation point of view.

The virtual prototyping project was transferred to another initiative, the Open Simulation Platform, in cooperation with DNV-GL, Rolls-Royce Marine, SINTEF and NTNU. A cooperation agreement was signed on 3 July 2018 – see photo 1. Activities in SFI MOVE were merged into this project in 2019.

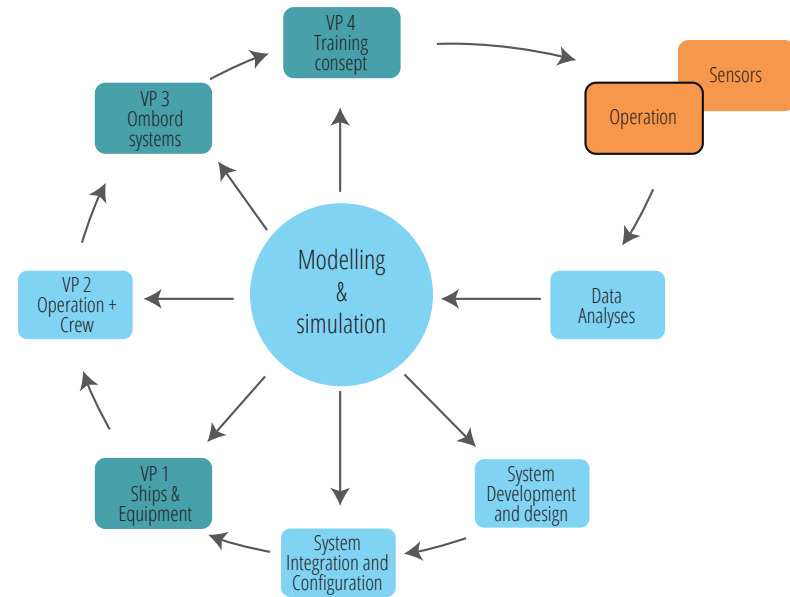

Figure 1: Virtual prototyping framework for marine operations.

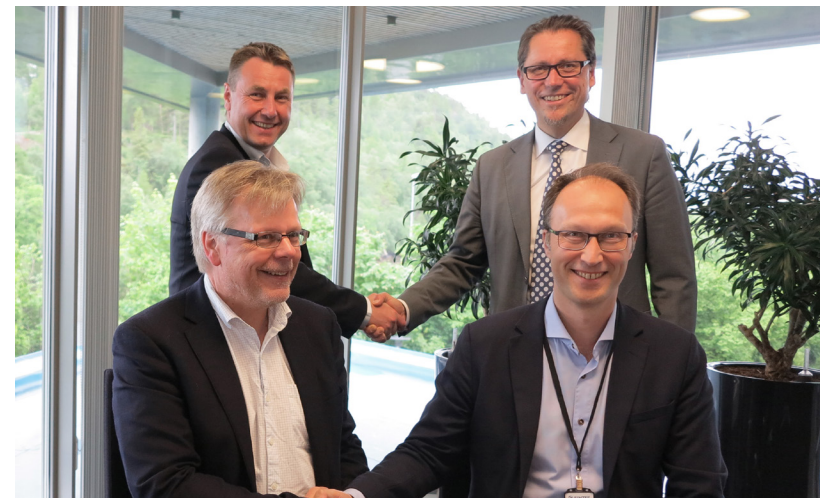

Photo 1: Signing a joint research project, "The Open Simulation Platform". In front Hans Petter Hildre (NTNU) and Henning Borgen (SINTEF Ålesund). In back, Asbjørn Skaro at Rolls-Royce Marine and Stian Eriksen at DNV.

Installation and service of offshore wind, bottom-fixed and floating structures

Installation and service of bottom-fixed offshore wind power plants were booming in the beginning of the SFI MOVE project. The cost for a wind field was reduced by a factor of 50 % over 2–3 years and reached a level where it became profitable without subsidies. The EU is likely to reach its target of 20 % of total energy consumption from renewable energy sources by 2020. Their future target is to increase the amount of renewable energy to 50 % by 2030.

Statkraft was at the forefront of this development in SFI MOVE. Installations were normally carried out with a jack-up ship and with high-lift cranes lifting the individual parts of the offshore wind turbine into place one by one. In total, this involves five individual lifting operations. The SFI's idea was to replace the jack-up with vessels and compensate for movement during the lifting operation. Statkraft changed its strategy at the end of 2015 and decided to work only with land-based wind power. It shut down its offshore wind activity and contribution to SFI MOVE

Equinor was at the forefront of floating wind systems and new research plans for floating wind were set up. An important driving force was to handle bigger turbines to reduce cost. With fewer restrictions on size and height than their onshore counterparts, offshore wind turbines are becoming giants. 12 MW turbines were installed in 2019 and Siemens Gamesa's massive 14 MW turbines produced their first electricity in 2021. The Siemens turbine has a rotor diameter of 222 metres and 260 metres high to the rotor centre. Even bigger units are in development.

Installations are moving further from shore, tapping better quality wind resources, and pushing up capacity factors. Next generation giant turbines demand new methods for installation, service, and repair. Installation of giant offshore structures is presently done using huge crane vessels with the required lifting capacities and height. Such assembly takes place in sheltered areas and the structures are then towed to the wind farm for mooring. This is a complex and costly operation.

The goal in SFI MOVE was to develop an innovative lifting solution using ships. The lifting force was to be attached at the lower point of the tower instead of using a huge crane higher than the wind turbine.

All-year subsea operations

The objective of SFI MOVE was to contribute to commercially viable and cost-effective marine operations, helping to position the Norwegian maritime industry in the market for such operations worldwide. As subsea field developments become more extensive, there is an increasing need for all-year marine operations. All-year operation will have a significant impact on technology, operational procedures, and cost, and will require very different solutions depending on the operating environment. There is a need for new methods, systems, and equipment to achieve the defined objective. Our aim was to establish a virtual prototyping (VP) approach for subsea operations.

Subsea installation and services have operational limitations due to environmental conditions such as waves, wind, currents, and water depth. In harsh environments, there will be operational limitations in performing marine operations.

Marine operations are designed, simulated, and planned long before the operation is carried out. Assumptions are made about the type of vessel, load condition, wind, waves, lifted objects' behaviour in air and sea, etc. The simulation results show that the operation can be carried out if a given sea state is not exceeded. Therefore, simulations are based on a series of assumptions and uncertainties. Significant safety margins are needed to compensate for these uncertainties. How can we reduce this uncertainty and then reduce Waiting on Weather (WoW)?

This project was expanded to include on-board support as well. Waiting on Weather can be reduced by bringing the analyses close to the operations and defining operations by measured and predicted responses. Using a digital twin technology facilitates go criteria for the operations in terms of vessel or crane response rather than met-ocean

parameters, which leads to more precise operational criteria.

Data from ship sensors combined with physics-based models are used to monitor and predict responses of the vessels and equipment used in the operation. Simulations will be performed in almost real-time and give advice to the crew performing a marine operation on how to operate safely and efficiently. The idea is to bring the analyses close to the operations and decisions based on actual responses. The simulations can be performed on board the ship or in remote operation centres. The sensor data from the ship then needs to be transferred to the remote operation centre. The technology developed will make an important contribution to response-based operations. This approach also links the simulation in the engineering phase to the operations phase.

Remote operations, a new project

The Centre Board wanted to pick one more project from the Innovation Plan as a new project from 2019. The project Remote Operations/Dispersed Crew was initiated. This project also supports the key objective for the centre. The purpose is to increase relevance and stimulate industrial interests. The content of the projects is gradually changing from exploration and solving fundamental problems to using results to solve industrial problems and create new tools and methods.

Marine operations are becoming increasingly technology based. New technological solutions such as digital twins, cloud computing and machine learning enable faster change and create more complex and dynamic work environments, which is followed by organizational changes, and implementations of new and more flexible structures and ways of working. The driver for such development is reduced costs through remote support replacing human support on board, as well as increased quality through access to a broader variety of competence and reduced risk through capacities to perform advanced analytics and trade-off scenarios. A remote operations framework can be established by adding a copy of the on-board digital twin to a remote centre. The sensors' signals will be transferred

to the remote centre and all responses will be calculated by the digital twin. Having a twin and simulation capacity at the remote centre gives several advantages.

- Low demand for transmission bandwidth
- Alternative scenarios can be executed while the ship is waiting
- The users in the operation centre can choose their view of interest

Summary of projects in the last period

The last period was planned by specifying final deliveries for the SFI MOVE.

1. Established a leading research and innovation centre for demanding marine operations
2. System simulation workbench for real responses:
 - A. Modular set of models allowing simulation of subsea operations and offshore wind installations (Functional Mock-up Interface (FMI)/Functional Mock-up Unit (FMU) modules)
 - B. Ship behaviour and data driven tuning of ship models
 - C. Prediction of future weather responses
 - D. Backbone of simulation capabilities from sales, engineering, on-board and remote operations
 - E. Front-end modelling and visualization environment
3. Methods and set-up for remote operations (based on simulation)
4. Demonstrators of technology. On-board and remote operations demonstrated for R/V Gunnerus and an offshore vessel (case: subsea lifting/installation)

In the final period, the work was concentrated in three projects. Final delivery for each project was defined and a roadmap defining year-year milestones was defined as shown in Figure 2.

**Project:
Operational responses in floating offshore wind installation and services**

Final delivery

Simulation workbench for offshore wind installations

A novel design for floating offshore wind

Road map

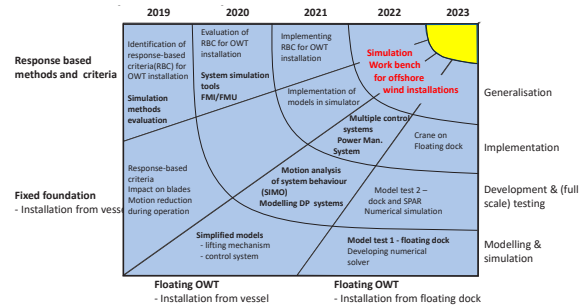

**Project:
On-board decision support tool for marine operations (subsea lifting operations)**

Final delivery

ODSS for subsea lifting operation. From lift-off to landing

Simulation tool covering areas from sales through engineering, to on board and remote

Road map

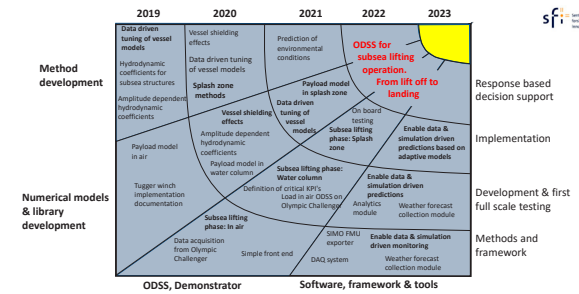

**Project:
Remote operations**

Final delivery

Full demonstrator of remote operations and dispersed team

A remote operation centre implemented as a demonstrator at NTNU

Road map

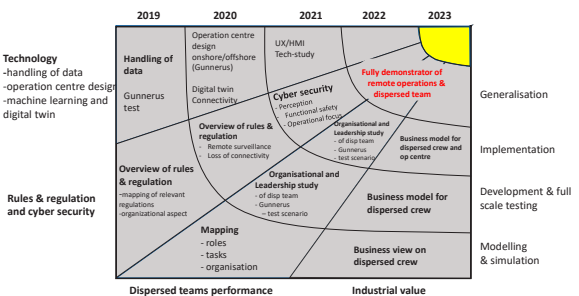

Figure 2: Roadmap.

Research achievements

Ocean Mining

The sub-project on ocean mining focused on the dynamic response of the riser needed for vertical transport of the ore material from the seabed to the vessel, as a basis for calculating the fatigue life, limiting the time window within which such operations can take place. The project was carried out as a collaboration between the Department of Marine Technology and the Department of Energy and Process Engineering at NTNU.

A 1D time domain riser flow model that included the water, stone and gas phases was developed and integrated by means of a full two-way coupling to the Riflex software for global dynamic analysis of riser systems. Meanwhile a time domain load model for Vortex Induced Vibrations (VIV) was also implemented into the same framework such that the effects from both internal flow, 1st order wave kinematics and VIV on riser fatigue could be investigated in the same model.

The prototype model developed included feeding the riser acceleration from the riser dynamics model into the 1D (SLUGGIT) flow algorithm, while receiving the mass flux from the 1D flow model as a basis for calculating the relevant forces in the riser dynamics code Riflex. The models were then forced to work along the same time axis, i.e. providing a full two-way coupling between the structural response and the internal as well as the external loads. The modelling principle is visualized in Figure 3, while the relevant coupling parameters are illustrated in Figure 4. The time varying load from the flow includes pressure, weight, centrifugal and Coriolis loads whereas the riser acceleration will change the direction of the acceleration then affecting the flow.

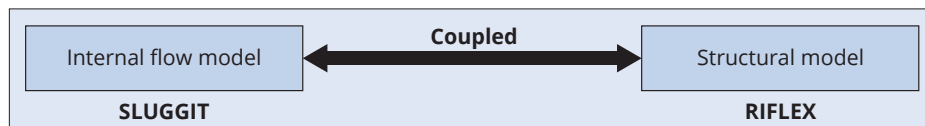

1D dynamic model: NTNU-SFI MOVE

Figure 3. The concept of a fully coupled model for calculating the riser dynamics during an Ocean Mining Operation.

The model was then applied to perform a case study on a steel riser for vertical transport, taking the Loke's Castle site outside Svalbard as a basis for selecting input parameters. The case study showed that the internal flow coupling might both increase and decrease the riser fatigue, depending on how the flow density waves are synchronized to the VIV motions, thus having the potential of controlling to some extent the weather window available for the ocean mining operation.

Installation of Offshore Wind Turbines (OWT)

The work in this sub-project was split between short-term and long-term activities. Since the offshore wind energy market is completely dominated by bottom-fixed installations, some short-term activities related to bottom-fixed OWTs were started initially. More long-term activities related to the installation of floating OWTs were also initiated, since it is expected that the development of offshore wind installations will tend to move towards deeper water, where bottom-fixed OWTs will be less realistic.

Installation of bottom-fixed OWTs

As an associated work to the SFI MOVE project, Yuna Zhao has in her PhD work studied the modelling and analysis of the installation of offshore wind turbine blades. The feasibility of floating installation vessels for single blade installation is studied by comparing the motions of the blade root relative to the monopile top for jack-up, mono-hull and semi-submersible floating installation vessels, as shown in Figure 5. The Morison's formula for hydrodynamic loads, the flexibility of the legs and the soil-pile interaction are considered for the jack-up vessel model, while the first- and second-order wave loads, and a dynamic positioning system were considered for the mono-

hull and the semi-submersible floating installation vessels. The comparison indicates that the large-displacement semi-submersible has slightly higher motions of the blade root as compared to the jack-up vessel, while for the mono-hull installation vessel the blade root motions are

too large. It is more feasible to use the semi-submersible than the mono-hull vessel for blade installation. Her work established a solid foundation for the PhD studies by Amrit Verma and Zhengru Ren, which were both conducted as part of the SFI MOVE project.

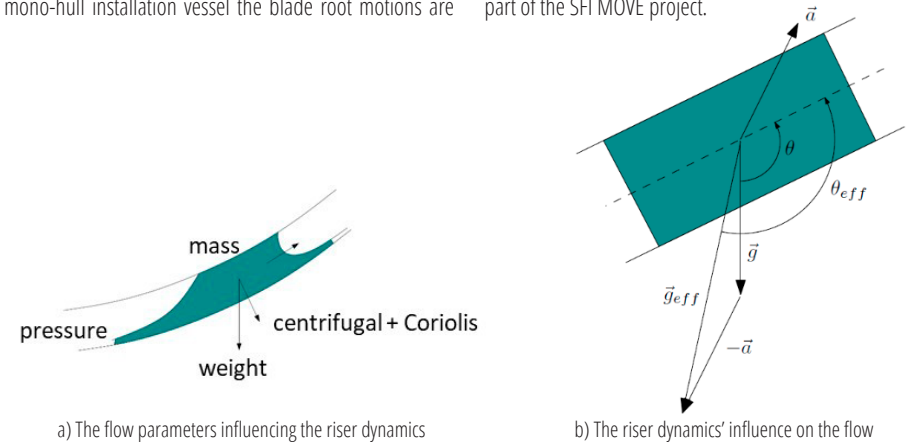

Figure 4. The physical quantities governing the dynamic loads during multiphase flow.

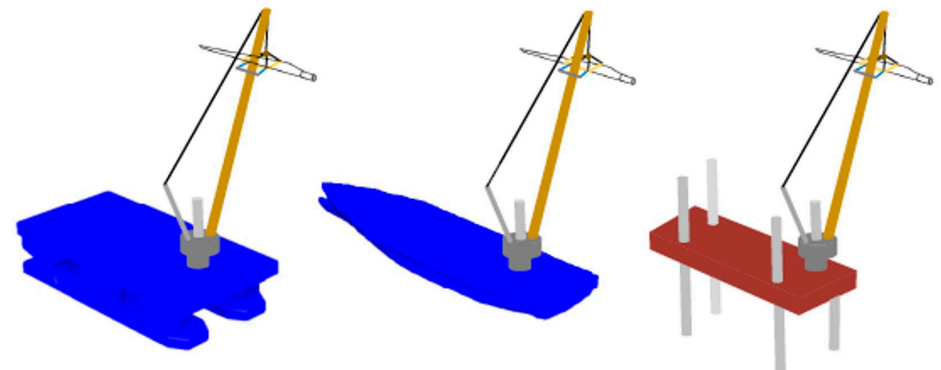

Figure 5. Offshore wind turbine installation using three different kinds of crane vessels: semi-submersible, mono-hull and jack-up. (From Zhao et al. (2019)).

In his PhD work, Amrit Verma studied the possible structural damage to the turbine blades from impact situations during the installation. Single blade installation in a lifting operation using jack-up and floating crane vessels was studied with a focus on blade root impact (operational loads) blade leading edge impact (accidental loads). A high-fidelity finite element model based on solid elements was validated with experimental results. Damage assessment of the turbine blades was carried out to establish failure criteria. Based on the established failure criteria, global response analyses were performed to assess the limiting sea states for blade installation. A mitigation measure was proposed by placing a passive tuned mass damper on top of the monopile. This was found to reduce the impact velocity between root and hub significantly, which can substantially increase the operability of the blade mating operation. A case study was performed to display the merit of the proposed methods. The mitigation method enables the operational limiting curve and operability to increase by 40 % using the proposed methodology.

Zhengru Ren studied control strategies to support the installation of offshore wind turbines in his PhD study. His focus was on the installation of blades for bottom-fixed offshore wind turbines using a jack-up vessel. He studied the whole lifting process of turbine blades from the deck of the jack-up installation vessel and up to the nacelle where they were safely mated to the hub.

A modularized simulation toolbox for the purpose of control design for single blade installation by crane operation was developed in MATLAB/Simulink. Based on the developed toolbox, an active tugger line tension control was proposed and demonstrated to be very effective in reducing the relative motion between the blade root and

the hub during the final mating phase of the installation. Through well-tuned weighting matrices, the non-linear model predictive controller (NMPC) can prevent snap loads and axial peak tension, while ensuring a safe and efficient lifting operation. Automatic control theories were used to optimize the blade installation operation by minimizing the relative motion between the blade root and the hub. Global positioning systems (GPS) were integrated with an inertial measurement unit (IMU) to provide high-fidelity hub motion estimations.

Installation of Floating Offshore Wind Turbines

An initial design of a floating installation vessel (a catamaran hull) together with an initial design of a low-height lifting mechanism was proposed in 2016. This included a gripper mechanism to reduce the relative motion between the floating installation vessel and the moored floating SPAR substructure and a hydraulically controlled lifting mechanism (see Figure 6). The main concern with this concept was the high contact forces involved (in the gripper mechanism as well as in the lifting mechanism) to reduce the relative motions between the OWT and the spar-shaped substructure.

An improved concept was proposed to reduce the interaction forces necessary to limit the relative motion between the OWT and the SPAR substructure. The lifting mechanism was updated and mounted on a motion-compensated platform which was designed to follow the wave-induced motions of the SPAR buoy; see Figure 7.

Following this approach, the concept evolved to an alternative where the OWT is held by a set of lifting wires and balanced by a set of stabilizing wires (see Figure 8). The relative motion is controlled by active winch control.

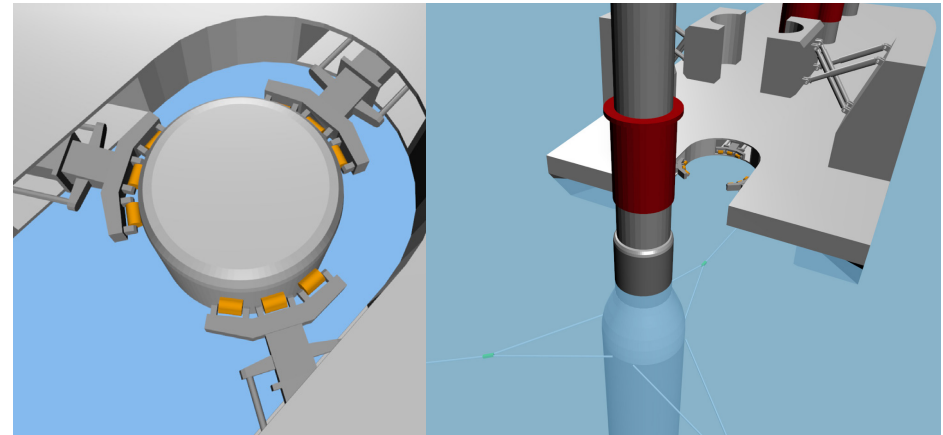

Figure 6. Illustrations of the gripper design and the lifting mechanism.

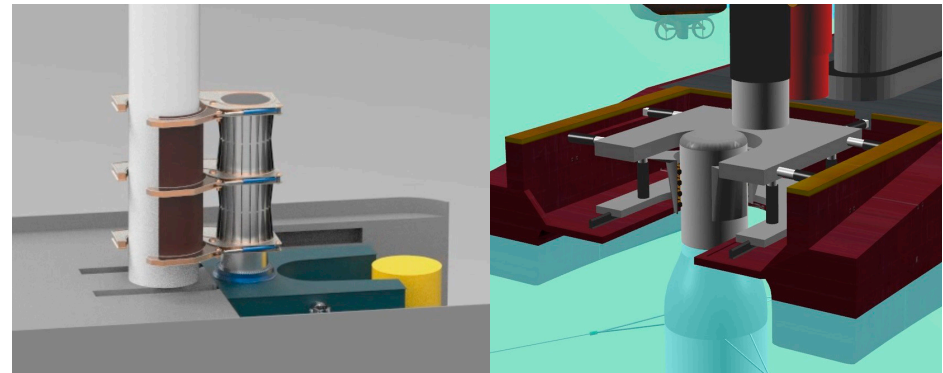
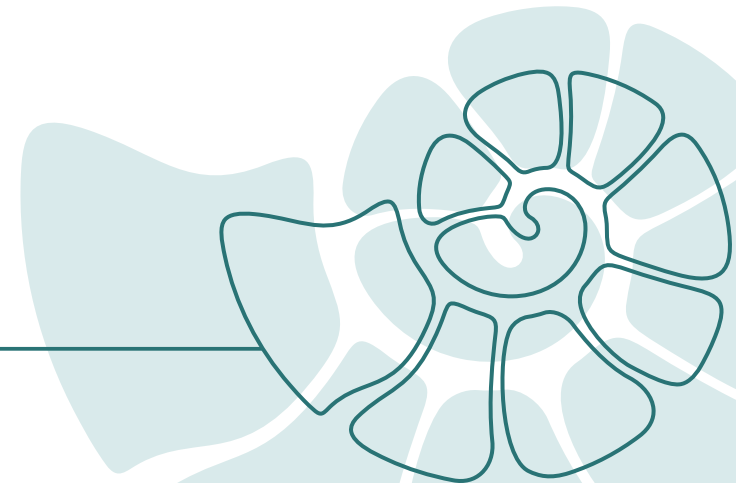

Figure 7. Illustrations of the modified gripper design and the motion-compensated platform.



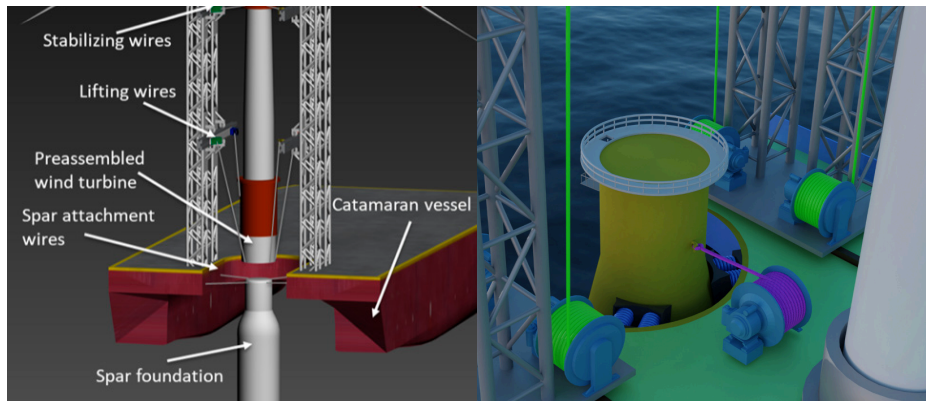

Figure 8. Improved Concept with separate lifting and stabilizing wires (left) and the mechanical damping device between the catamaran and the SPAR (right).

Inspired by the knowledge of inverse dynamics and range-based localization, a model-free controller was developed. It has a simple control design and the freedom from building the control allocation matrix.

The concept was improved in several steps. The relative motion between the moored floating SPAR substructure and the DP-controlled floating installation vessel was reduced by introducing a fender system in combination with a pretensioned wire system to keep the two floating bodies in tight contact.

The main challenge for the proposed concept was to reduce the relative motion between the lifted OWT tower and the floating substructure (the SPAR buoy). Several case studies were completed to support the performance of the simulation workbench.

A mechanical damping device (consisting of fenders and pretensioned wires) was introduced between the floating SPAR buoy and the vessel, to reduce the relative motion (see Figure 8). The spring stiffness of the fender and the pretension in the wires were varied to study the effect on the system response.

1. A finite element model of the jacket-like crane structure with realistic stiffness properties (or flexibility) was modelled and simulated in a dynamic

analysis. The dynamic response of the crane top was compared to the response from simulations where the crane was assumed to be a part of the rigid body motion of the vessel.

2. The pitch motion of the catamaran is one of the dominating factors to influence the relative motion between the SPAR and OWT, and in order to overcome the effect of the pitch motion, an alternative installation concept at the midship was proposed. A comparison study where the mating point was located at the stern of the catamaran, at the side of the catamaran (approximately at the midship) and in the centre of the catamaran was carried out; see Figure 9.
3. The preliminary conclusion from our initial operability analysis with the alternative concept is that the operational limits are significantly increased if we move the installation to the midship or the side. The side installation may introduce new challenges (e.g. from static inclination or roll motion), but the alternative installation concept is promising.
4. A comparative study with an alternative installation vessel (a small water-plane area twin-hull vessel (SWATH)) has been completed. The conclusion is that the response of the SWATH is less than the catamaran and consequently that the relative motion between the vessel and the SPAR is reduced.

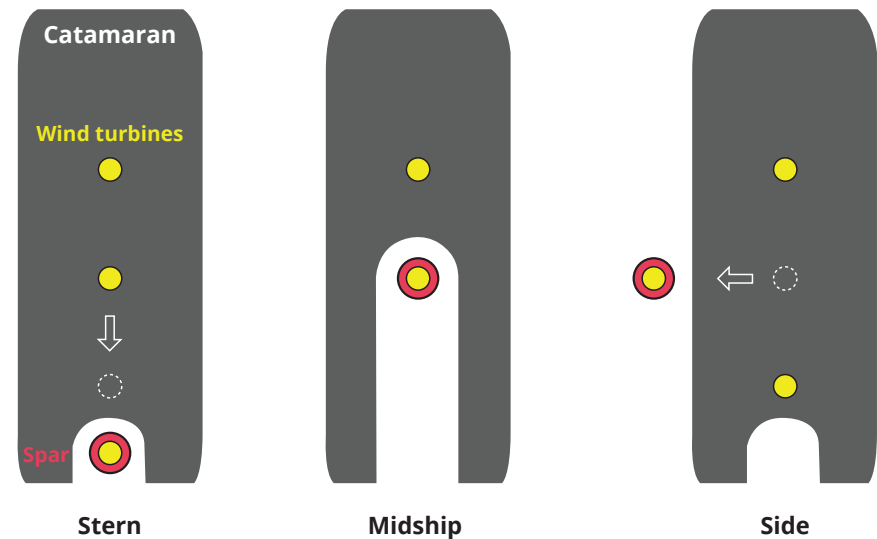

Figure 9. Three different installation arrangements (Stern, Midship, Side)

5. A quick connection device between the OWT and the SPAR is designed to reduce the time needed for mating of the OWT and the SPAR. Analyses were performed to study the impact loads between the two objects during mating.

Modelling issues

During the design of the proposed installation concept, several software tools were used to assess the dynamic behaviour of the system. The hydrodynamic behaviour of the floating objects (the installation vessel and the spar-shaped substructure) has been established using the HydroD module Wadam. Dynamic analyses of the coupled system have been carried out using both SIMO and Orcaflex, both of which have excellent models for including the hydrodynamic characteristics of the floating objects. However, the functionality to model and analyse complex mechanical/hydraulic systems are less developed in these software systems. Other tools (like AGX) have excellent models for the mechanical/hydraulic systems but are

less flexible with respect to include proper hydrodynamic models. Furthermore, most of these software systems lack the functionality to include realistic models for advanced control systems.

Simulation workbench for wind turbine installation systems

To overcome these challenges, a co-simulation approach was adopted. Co-simulation techniques allow for a combination of various specialized domain tools to act together in concert. To succeed with the co-simulation approach, one need to

- ensure proper connectivity between the FMUs (avoid tight coupling problems)
- ensure both dynamical and numerical stability of the system
- reach a satisfactory accuracy by using proper communication time step
- and to be useful in an on-board decision support system, close to real-time behaviour must be ensured

The co-simulation approach was tested on a simplified system to achieve control with the approach and address the various challenges mentioned above. Based on this, the computational performance was improved significantly by using the software AGX to make the FMUs instead of the initial OrcaFlex attempt.

A preliminary modularization solution was developed for the FMI-based co-simulation of the whole system, see Figure 10. Separate FMUs are made for the OWT, vessel, and spar based on OrcaFlex. Secondary controlled winches are packaged as FMUs in 20-sim for the lifting and stabilization. In addition, controllers involving simplified control algorithms are made as FMUs for winch control and dynamic positioning (DP) control, respectively. The Vico platform developed by NTNU in Ålesund was applied to test the co-simulation performance. All the FMUs are parameterized and connected with each other based on system structure and parameterization (SSP) standard. The results have been compared with the relevant monolithic simulation, and although there are some accuracy and efficiency issues, the results so far are promising.

Installation of Floating Offshore Wind Turbines from a Floating Dock

In an attempt to shelter the installation process from waves, SFI MOVE introduced a large “floating dock” concept. The floating dock concept is intended to shield a spar floating wind turbine during installation of the tower, nacelle, and rotor onto the spar foundation. First, design optimization of the dock was performed to minimize the material cost. During the optimization, multiple design variables and non-linear constraints imposed by operational and transit conditions were addressed; see Figure 11. Then, hydrodynamic analysis and dynamic response analysis of the coupled system of the dock and the spar were conducted.

As part of a PhD work by Maël Moreau, a potential code was developed for the floating dock and a floating spar inside. The code also includes empirical estimates of the viscous effects inside the dock where internal baffles are designed to increase the hydrodynamic damping of the floating dock. Model tests were carried out to understand

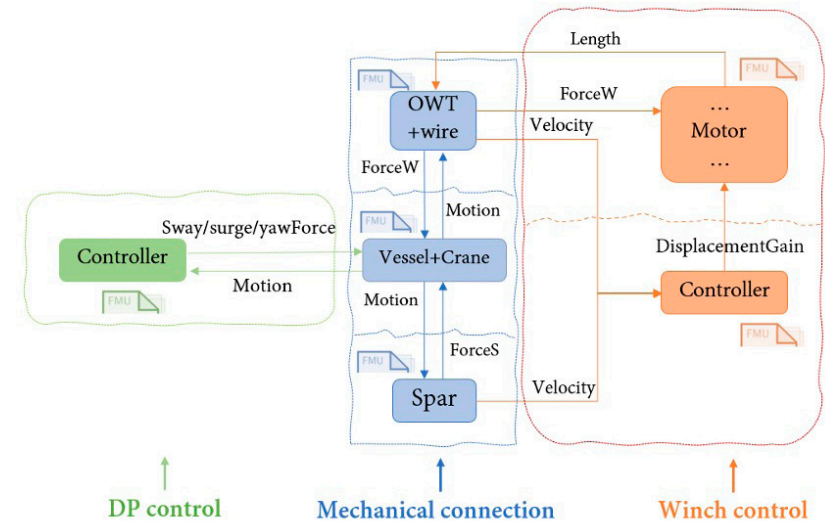

Figure 10. FMUs based on proposed modularization.

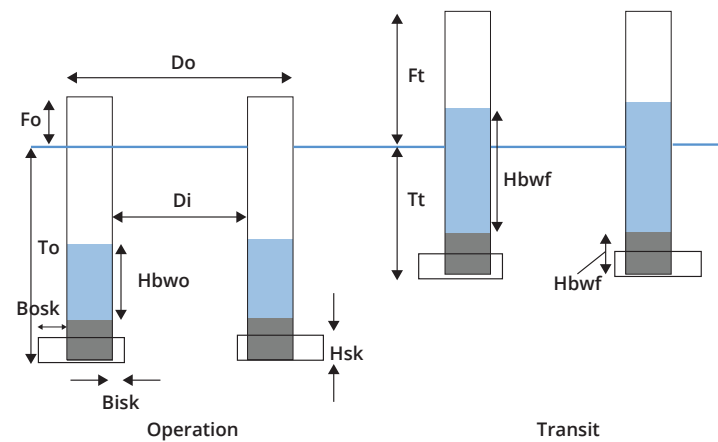

Figure 11. Illustration of the design variables of the floating dock.

the behaviour of the floating dock in waves. The sloshing induced motions of a floating wind turbine's spar inside the cylindrical floating dock were investigated for both regular and irregular incident waves. The reduction of the lowest natural sloshing frequency was a notable consequence of adding the spar inside the dock. Analytical results were compared to experimental results with a fair agreement, revealing a significant sensitivity of the amplitude of the motions to the moment of inertia in pitch of the dock, and to few other parameters related to the mass distributions and the geometries of both the spar and the dock. Various damping devices (both solid and perforated baffles, see Figure 12) have been tested with encouraging results. The solid baffle at small submergences damped the sloshing waves the most efficiently, reducing the resonant peak by more than 55 %, which could help to meet the required criteria for the assembly of floating wind turbines in site at operational weather conditions.

Short-term deterministic forecasting of wave fields

The main objective of this activity was to improve the safety and efficiency of marine operations. Three alternative approaches were followed:

- Very short-term (tens of seconds) prediction of waves. When the stochastic weather forecast is not

satisfactory, the deterministic forecast of waves may discover short openings in otherwise closed weather windows (see Figure 13). The weather forecast is based on measurements from a wave radar. It is not possible to deterministically predict the sea surface elevation for the entire ocean. The predictable zone depends on the size of the measurement zone and on the group velocities of the shortest and longest waves. This may allow for marine operations to be performed – leading to all-year-round marine operations.

- Very short-term prediction of wave-induced motion. Based on measurements of the vessel response, (as well as measurements of the present sea state) the numerical model of the vessel is tuned by a neural network to minimize the prediction error, thus allowing the vessel model to better represent the hydrodynamic characteristics of the vessel. This will allow for more accurate predictions of the vessel response and open for safer execution of marine operations.
- From radar images, updated and actual wave spectra can be established. This may be an important contribution in planning of marine operations and in on-board decision support systems. More accurate assessment of the safety margins for the next few days can be found by using tuned numerical models.

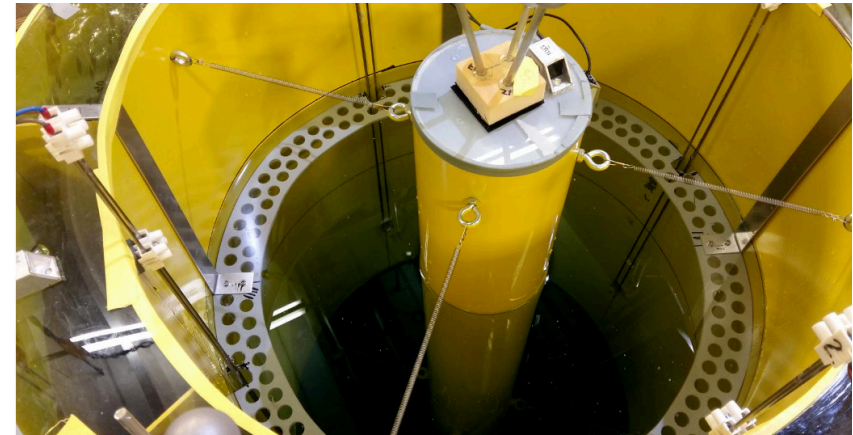

Figure 12. Floating dock with the spar of a Hywind wind turbine inside

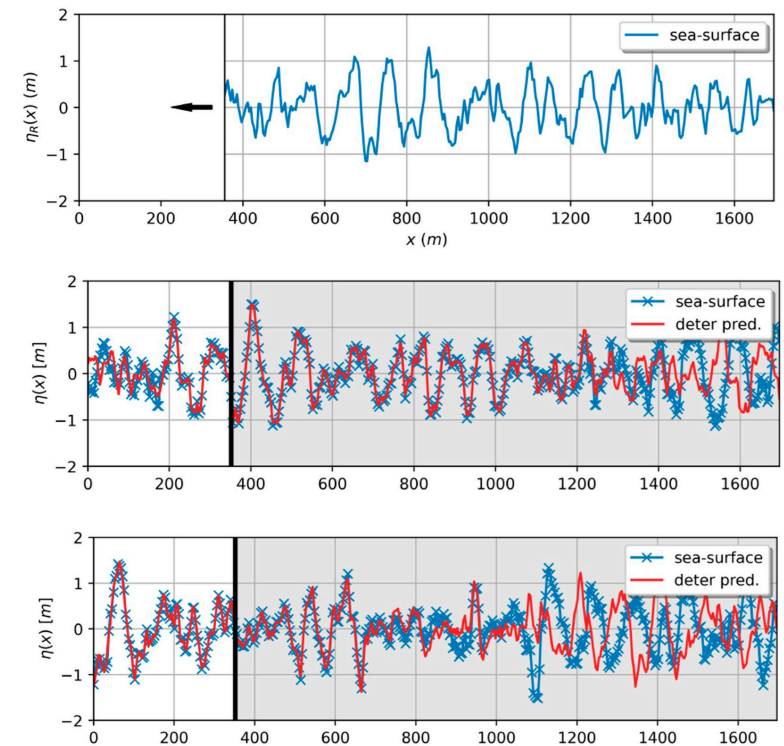

Figure 13. Forecasting of wave fields. Based on a “scan” of the sea surface (top), the wave field is predicted after 60 s (middle) and 120 s (bottom). The figures show both the predicted and the actual wave elevation.

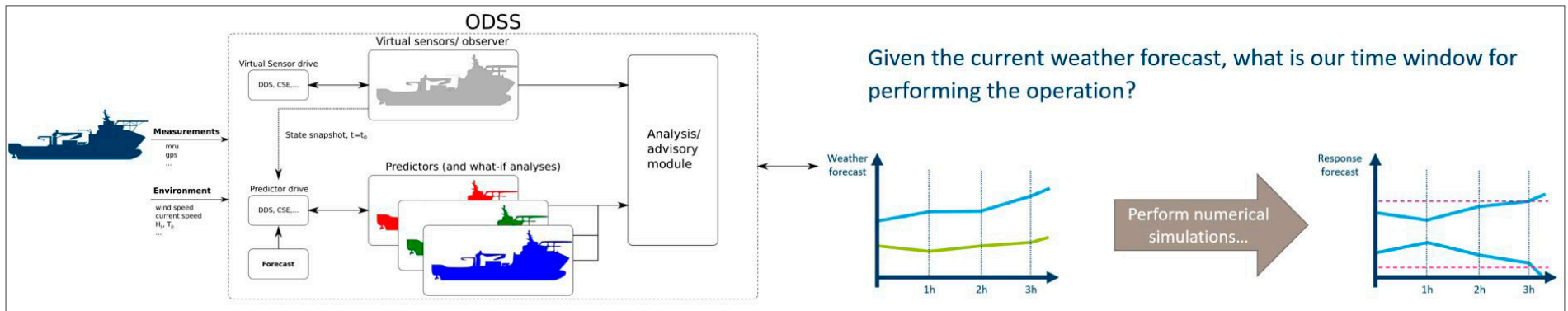

Figure 14. Main components and interfaces in an ODSS architecture.

On-board Decision Support Tool for Marine Operations

The on-board decision support system (ODSS) effort in SFI MOVE has developed knowledge, methods and technology on how to use operational data from ship sensors, combining these with physics-based models, to monitor and predict the response of the vessel and its working tools (e.g. lifting equipment), and based on this information, to give advice to the crew performing a marine operation on how to operate safely and efficiently. The technology developed will make an important contribution to response-based decision making in marine operations. The work undertaken in the ODSS effort has consisted of a mixture of activities linked to three of the original MOVE research areas: “Vessel performance” (RA1), “Enhanced physical modelling, numerical methods and tools” (RA2) and “On-board systems” (RA3).

On-board decision support system (ODSS) architecture

The work conducted in the on-board decision support system architecture activity has been ongoing since SFI MOVE started in 2015-2016. In 2018 and early 2019, basic concepts and architecture of the framework was formulated, illustrated in Figure 14. Examples of framework components were implemented, and at the 2019

MOVE Autumn Conference a simulation fed with real-time measurements was demonstrated. The simulation can be combined with “virtual sensors” that provides additional information which are not available through direct monitoring. This was demonstrated in the context of the “load in air” phase of a lifting operation. At the 2020 MOVE Autumn Conference another piece of the puzzle was demonstrated; namely how predictive simulations can give useful information about the limiting criteria for an operation. In this demonstration the focus was on the “load in splash zone”. In 2021 the focus was geared towards adaptive vessel models, where historical and/or live measurements were used for tuning key vessel parameters to improve both the system understanding as well as the operational safety and to increase the available operational window.

In 2022 the work on writing a document named “An architecture for on-board decision support systems” was started. A rough draft was distributed to selected industry partners for review and feedback, and the report was finalized in March. This report summarizes the work and findings from the ODSS architecture activity. It is believed that this document can become a solid foundation for the next stages of development, e.g. as spin-off innovation projects with the goal to lift the ODSS architecture

research results to an industrial product. In addition to a description of the architecture, the document includes several case studies that demonstrate and validate the flexibility and robustness of the approach and design.

Data driven ship model tuning methodology

In the earlier years of SFI MOVE, the model tuning method and software have been tested with data from laboratory model tests and simulations. Havfram AS has made a large amount of measured (“real”) data of motion and waves from the offshore service vessel Normand Vision available. In addition, field experiments with the vessel R/V Gunnerus were carried out in 2021 and 2022. The wave data experienced by the two vessels were measured with wave radar, which also provides information of the directional spreading. A numerical model for Normand Vision exists from previous years. For R/V Gunnerus a numerical model was established and reported in 2022. Both models are ready for tuning.

The amount of data from Normand Vision is large and was recorded continuously in time, regardless of what the vessel was doing (i.e. during transit, when loading at quay as well as during operations). In 2022 a considerable effort was used to find the time intervals when the data were relevant from a marine operation perspective and of good quality at the same time. This work is described in a separate report. The data from R/V Gunnerus were measured during a planned offshore campaign, and all the data are relevant and suited for tuning.

An important goal for the work in 2023 has been to see if wave data obtained with radar can be used for model tuning. It must be expected that considerable uncertainty exists in the wave spectra. The measured vessel motion, on

the other hand, is of good quality. The numerical model has some initial uncertainties. In general terms the measured wave spectra are useful, therefore, only if they are “less uncertain than the parameters of the initial model”.

Vessel shielding effects

In 2020 the important task of establishing a method for including vessel shielding effects on a lifted object was started. During 2021 a prototype version of this method was implemented in the simulation tool SIMO. The new method and implementation were presented at the 2021 MOVE autumn conference, using the Johan Sverdrup ITS installation as case study, where the ITS (the lifted object) consisted of a number of slender elements. It

was demonstrated that the shielding effect significantly reduced the tension in the main wire as compared to previous analysis which did not take this effect into account. In addition to taking the shielding effect into account, the new method uses a new and more efficient calculation method, and for the mentioned ITS installation analysis the total simulation time was reduced by approximately 50 % compared to the previous analysis. This will be an important feature to incorporate in numerical tools forming the basis of predictors to utilize the shielding effect the crane vessel will have on lifted objects.

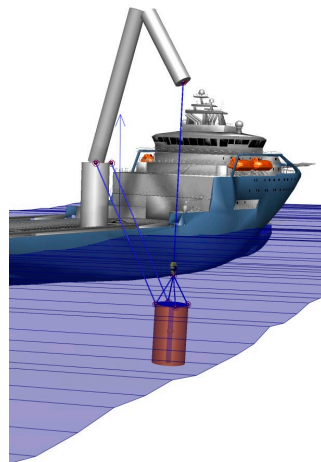

RV Gunnerus



OSV Normand Vision

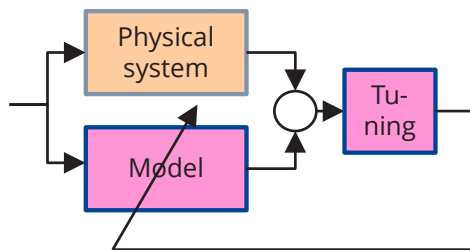

Principles of data driven ship model tuning.

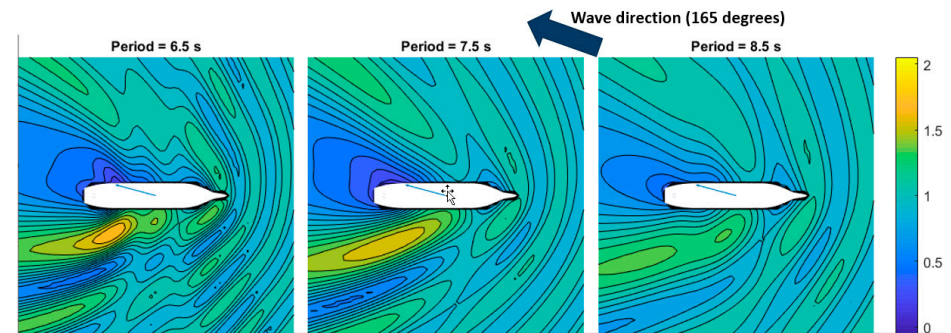

Wave height amplification factor due to shielding effect.

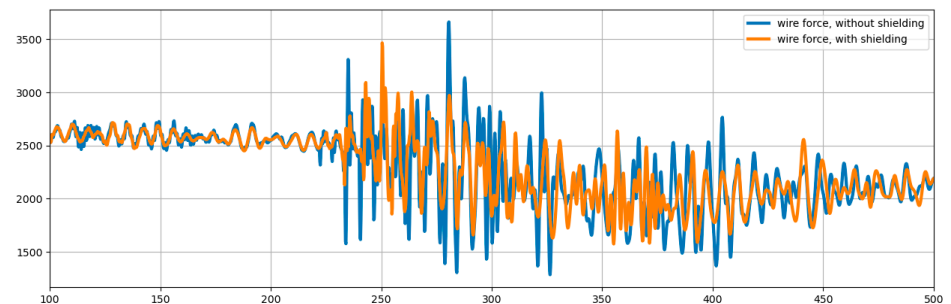

Comparing tension in main wire during installation analysis, with and without shielding effect.

Hydrodynamic coefficients for subsea structures

The activity on hydrodynamic coefficients has been ongoing throughout the MOVE project period. In 2021 the focus was on how the subsea equipment inside a module with protection roof and mudmat influence on the hydrodynamic coefficients. The main findings are that for the generalized modules tested, damping is generally the dominating hydrodynamic force. However, the presence of content inside the module will increase the importance of added mass compared with a module consisting of only roof and mudmat. Estimation of coefficients by summation of the coefficients for the individual structure parts was also studied. It is seen that the damping will generally be overestimated when

estimated as the sum of the damping for the individual elements, compared with model test results of the entire module. If the module consists of both mudmat and roof, with and without internal content, estimation of added mass by summation is good. On the other hand, for structures without a roof or a mudmat, estimation by summation will underestimate the added mass.

To obtain good numerical models of an installation operation with reliable results, realistic hydrodynamic data for the structure to be installed are crucial. Based on old MARINTEK model test results from 1985 to 2013, added mass and damping for subsea structures and structure parts have been collected and presented in three SFI MOVE reports for future use.



Laboratory set-up for hydrodynamic testing of a different substructure.



The three reports summarizing the work on hydrodynamic coefficients.

Guide on numerical modelling and simulation of offshore lifting operations

Numerical modelling and simulations of the deployment of complex subsea structures are used to obtain limiting sea state for the operation and to assess forces in the

lifting equipment and on the structure. Based on earlier experience and knowledge obtained in the MOVE project, a first version of a report with advice and examples that may be useful in the development of such numerical models was delivered at the end of 2019.

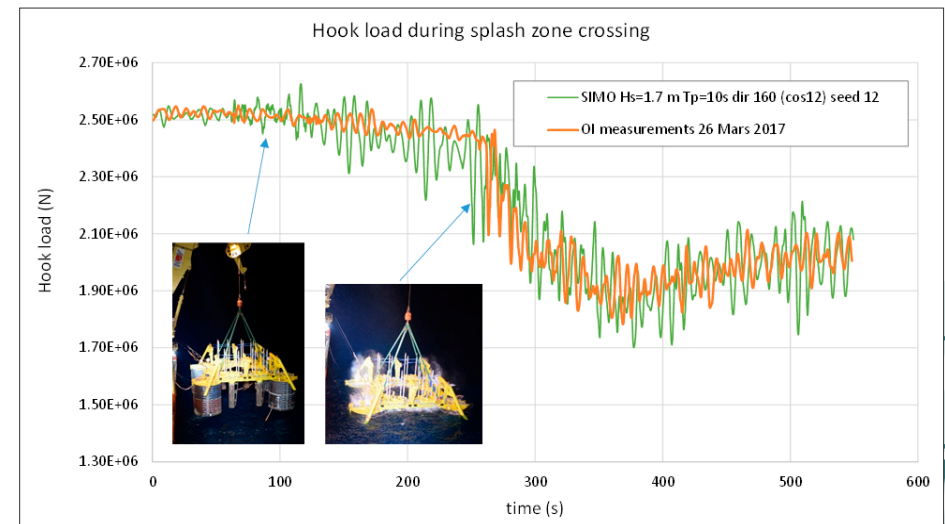
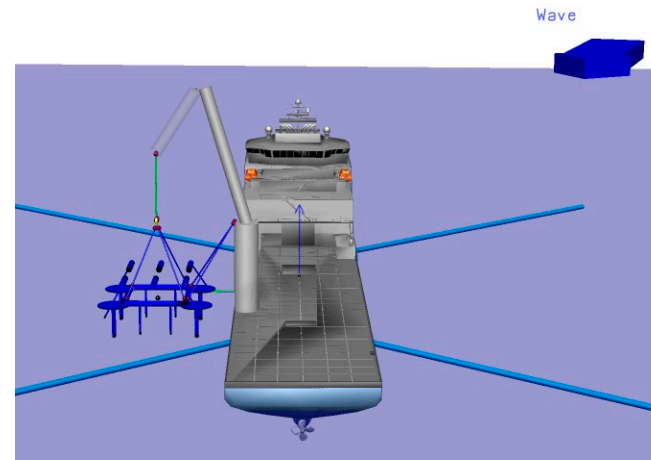

Guide on numerical modelling and simulation of offshore lifting operations.

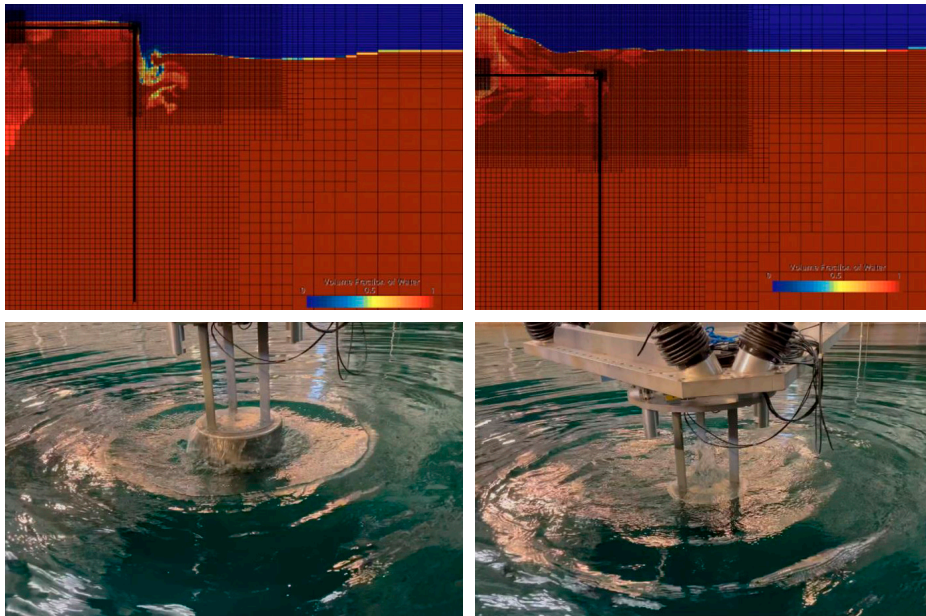

Snapshots from CFD simulations and model tests from forced-motion simulation/tests. Left; Suction anchor above the surface at the end of motion cycle. Right; Suction anchor below the surface at the end of motion cycle.

The report is not intended to be a complete user's manual or recommended practice for numerical modelling of installation operations. The main topic is estimation of hydrodynamic coefficients for subsea structures and how to model them. That said, some additional tips and tricks from experienced users regarding modelling of the complete system with vessel and lifting gear are included. Examples are given of how hydrodynamic coefficients for the structure to be installed may be estimated based on published data. It is shown how a suction anchor may be modelled by use of the slender element model in SIMA and how depth dependency of the coefficients may be used for splash zone crossing. Calculation of slamming forces by use of the slender element model and depth dependent coefficients are considered. Estimation of extreme response by use of the stationary approach and from lowering simulations are illustrated.

New findings and knowledge during the last years of MOVE, focusing on practical numerical modelling of installation operations, were added during the period 2022–2023. A revised version of the report was delivered in May 2023.

Splash zone hydrodynamics

The activity on splash zone hydrodynamics has been ongoing since 2020. The work in 2022 mainly focused on suction anchors and modelling of hydrodynamic forces for such structures in SIMO. SIMO models need hydrodynamic coefficients to estimate the corresponding hydrodynamic forces. Estimation of hydrodynamic coefficients were performed using both model tests and CFD (Computational Fluid Dynamics) in the free surface zone. Wave tests were also performed to have validation data for excitation forces when the SIMO model was examined. Snapshots from

model tests and CFD simulations are shown below. In the CFD simulations 1/4th of the suction anchor was modelled due to double symmetry.

A SIMO model has been prepared to use the calculated hydrodynamic coefficients for simulations of the suction anchor in waves. Extensive studies were performed using WAMIT (Commercial code for computation of hydrodynamic forces) to examine the SIMO model for estimation of excitation forces near the free surface. In 2023 the splash zone activity, with suction anchor as case, was further pursued to come up with a model with acceptable accuracy to be shared with the industry partners. The results of the CFD simulations, model tests and SIMO model was reported in 2023.

Parametric seakeeping optimization tool

The aim of the seakeeping optimization tool activity has been to provide a tool to simplify the optimization of ship motion characteristics and to improve seakeeping performance for specific operational tasks and sea areas. This mission-dependent optimization approach involves adjusting hull dimensions and loading conditions, to ensure that important responses like pitch and roll are distinct from dominant wave periods. The approach can also be utilized in the on-board decision support context, allowing a more accurate prediction of the loading condition dependent roll response. In 2022 the seakeeping optimization tool for parametric studies was further developed and tested. The parametric vessel optimization tool is integrated in the existing seakeeping code VERES and is now available to project partners as updates to the ShipX 4.2 workbench.

Identification of the best vessel for efficient task execution

REQUIRED Mission oriented vessel performance evaluation process



Parametric seakeeping optimization tool.

Vessel Response Tool

A Showcase for Response-Based Design Optimization

Open-access on vrt.sintef.no

The Vessel Response Tool (VRT) is designed for supporting decision-making processes where a quick analysis of motion response behavior of different ship designs for benchmarking or vessel selection is needed. The tool enables the user to evaluate and compare mission dependent ship motion behavior based on the vessel's main characteristics, motion limitations, and environmental data only. The tool delivers a validated* approximation of selected performance parameters, such as limiting sea states, percentage operability, and the Operability Robustness Index (ORI).

Vessel data
Default values can be changed within a predefined range.

Vessel 1

Overall length: 100 m

Beam: 21.4 m

Draught: 7 m

Metacentric height: 2.40 m

Vessel 2

Overall length: 120 m

Beam: 24.3 m

Draught: 7 m

Metacentric height: 2 m

Vessel 3

Overall length: 140 m

Beam: 27.3 m

Draught: 7 m

Metacentric height: 2 m

Add vessel

Operational data

Ship speed: 0 km

Heading: 45 deg

Sea Area: North Sea (56.5N, 8.2E)

Season: Winter

Sea spectrum: JONSWAP

Gamma: Variable

Limitation Criteria

Motion: Roll

Motion type: Displacement

Statistical type: Expected maximum

Max. allowable value: 4.0

Onboard location: Centre of gravity

X as a factor of length: Prod. AP
Example: 0.5 = vessel length / 2, Prod. AP

Y as a factor of beam: ORI parameter positive to expected wave
Example: 0.5 = vessel beam / 2

Z as a factor of beam: Allow flexible

Add Criteria

Calculate vessel performance

*The analysis is based on a large database of transfer functions, calculated for a generic hull of a modern offshore construction vessel. A comparison of a variation of hull geometries leads to an accuracy level (standard deviation) for the ORI (generally measured ORI of 2% for roll, 3.3% for pitch and 1.8% for heave at CG). For further information please refer to the OMA(2017-02-07) providing Design Parameters for Increased Operability of Offshore Crane Vessels.



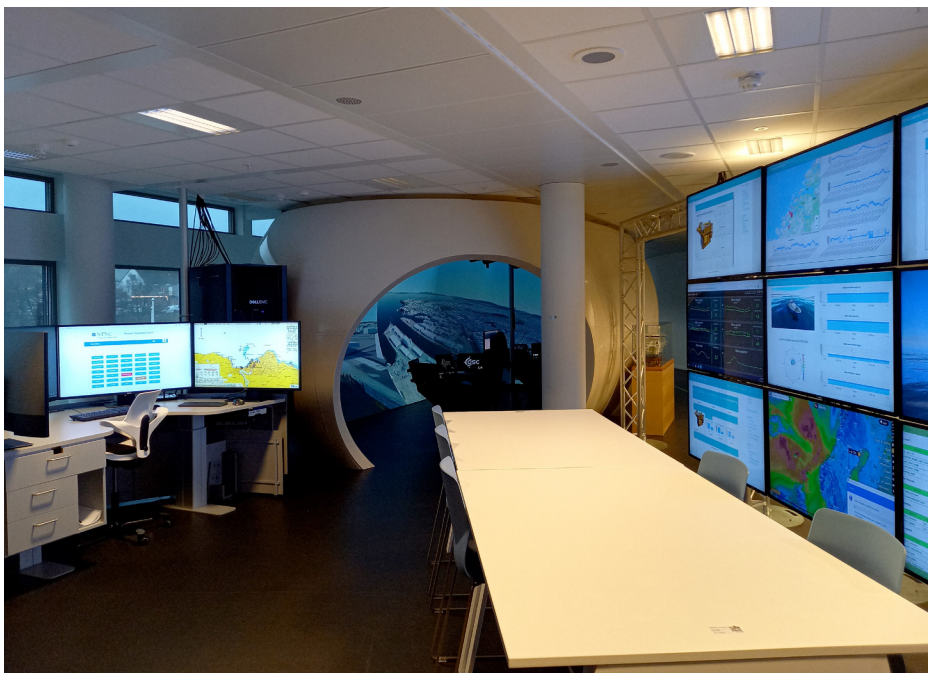

The Remote Operation Centre at NTNU in Aalesund.

Remote operations and dispersed teams

This project on remote operations focused on how use of digital twin technology can enable collaboration between shore and vessel, development of cyber security solutions, and how dispersed teams and digital transitions in remote operations can optimize workflow and organizational change. The focus was on how technological development in the maritime industry creates opportunities for optimization and increased safety in marine operations.

Project activities were structures using the HTO framework (Human-Technology-Organization), and the research activities have centred on data collection from simulator experiments, collaboration with industry partners, site visits, development of new business models and cost-benefit analysis. Amongst other things, we have tested our Remote Operation Centre (ROC) and digital twin

technology, developed a cyber security course for maritime managers, and investigated new business models for remote operations. In 2021, we made a promotion video of our ROC and digital twin of the research vessel Gunnerus (link to video:

<https://www.youtube.com/watch?v=lt0Yw6mZlpM>).

The final deliveries presented below are the case deliveries within the following main project activities: testing of ROC and situational awareness, business case, and technology and cyber security.

Testing of ROC and situational awareness

Within this project, simulator experiments were conducted during 2021 and 2022 with use of NTNU's ROC and research

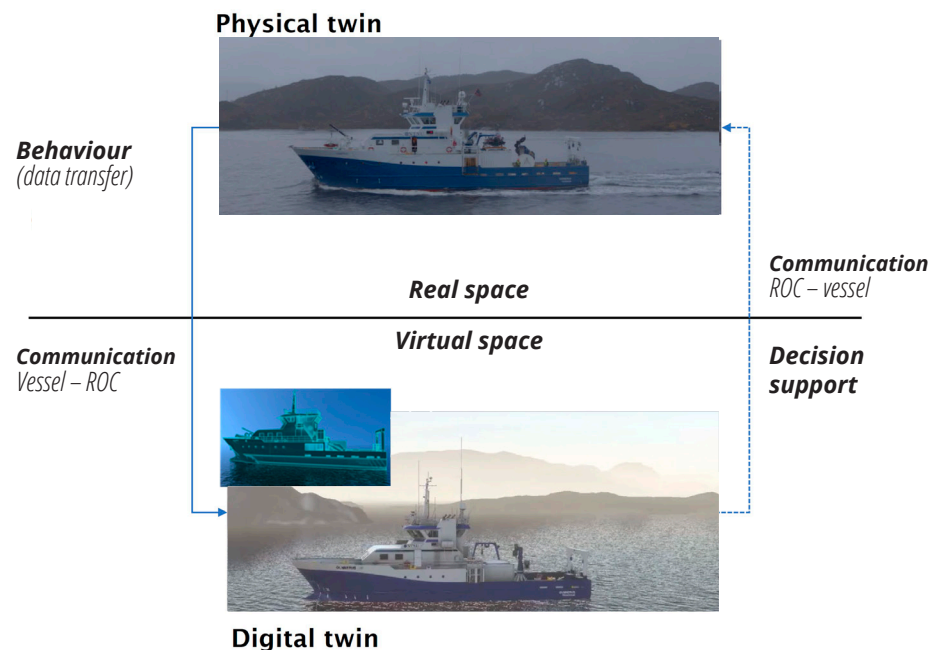

Figure of the digital twin of R/V Gunnerus.

vessel Gunnerus. The objectives of these experiments were to test usability, communication solutions, and situational awareness in the simulator set-up. The scenarios chosen for the experiments were executed in real time with use of our digital twin, R/V Gunnerus and nautical students.

Results of the simulator experiments showed that integration of sensor data can enhance usability if the interface is adjusted to the needs and competences of the operator. When we tested the communication between the ROC operators and the crew on R/V Gunnerus, the results indicated that existing communication solutions (voice/video/chat) can make it possible to solve a simple task. However, there is a need for more integrated communication solutions if the tasks at hand are complex and the collaborating team members (onshore and offshore) are highly dependent on each other.

The project successfully tested the remote operation centre set-up in real time and has provided evidence of the opportunities with use of sensor data and digital twin technology to enhance certain aspects of marine operations. This concept is still a work in progress, and we aim for additional research projects to fully comprehend the opportunities and challenges by introducing more remote ways of working within the maritime domain.

Business case

Extensive research has been conducted to examine the impact of remote operations in the maritime industry on organizational models and the relationships between ships, shipowners, and third-party suppliers. It has been established that remote operations introduce new

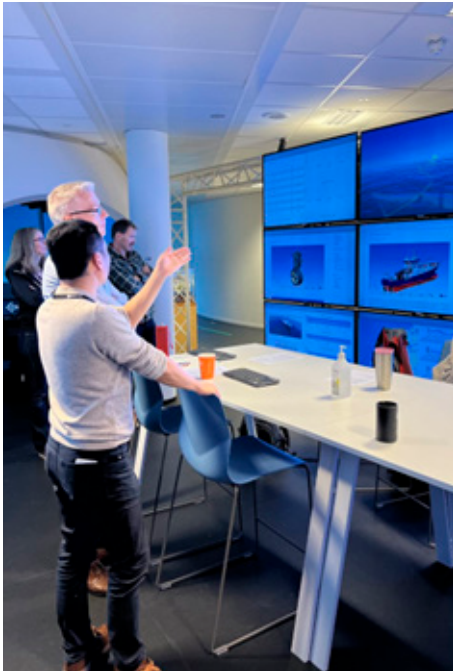

Use of sensor data for decision support and predictions in ROC.



Preparing for cyber security drills in maritime bridge simulators.

dynamics that necessitate the development of innovative business models. The focus of the research has been to explore potential changes in the business models of organizations as a result of transitioning to remote operations and working with dispersed teams. Objectives of the study were to understand how the next generation of digital services is affecting business value, i.e., how the quality of the decision making is affecting income, expenses as well as other non-monetary performance.

Throughout the project, several key findings were achieved. A study on energy efficiency and green solutions in the Norwegian maritime industry highlighted the development of new technologies and environmentally friendly vessel types. The evaluation of R&D activities in the maritime industry revealed that R&D expenditures and

turnover from product innovations positively contribute to value creation and sustainable transitions. The research on new business models in the maritime industry recognized the impact of digital transition and emphasized the importance of developing new business models to adapt to changing relationships and collaboration between actors. From a supply chain perspective, the study on integrated sustainable value creation emphasized the importance of stakeholder engagement, social responsibility, and future competence requirements. Lastly, the study on the interplay between technological innovation, energy efficiency, and economic growth confirmed the positive impact of new technologies on energy efficiency and emphasized the importance of technological capability for countries to achieve sustainable growth.

In conclusion, the project successfully achieved its

goal of exploring the impact of remote operations on organizational models and shareholder value in the maritime industry. The findings highlighted the industry's commitment to sustainability, the importance of research and development, the need for new business models, and the positive impact of technological innovation. These insights provide valuable knowledge for decision-makers in the maritime sector, enabling them to navigate the changing landscape and optimize their operations for long-term success.

Technology and cyber security

Another focus of this project on remote operations was on technology development and cyber security training. The work with transferring and visualization of sensor data

from R/V Gunnerus to the ROC was completed during this project. System performance and front-end designs were tested in the simulator experiments mentioned above.

The results showed that the system performance was sufficient to run scenarios in real time, but we experienced occasional loss of signals due to topography and 4G coverage. The visualization of sensor data provided the ROC operators with information about the environment and ship performance. Even so, we found that there is a need for further development of operator-specific dashboards and a change of placement of information sources. Future work should address how the remote operation centre can be more technically resilient, look at development of operator-specific dashboards, and investigate integrated communication solutions.

With increasing digitalization and connectivity in marine operations, the cyber-attack surfaces expand. This requires a holistic approach to cyber security in all phases of marine operations. We conducted research on maritime decision-makers' perception of cyber risks, and the results showed that it is important to understand human behaviour to develop targeted cyber risk management strategies. This work contributed to the development of a maritime cyber security course, which was given to maritime personnel during January and February 2023. The focus of the course was on cyber security basics, cyber risk analysis, and training on cyber-attacks in maritime bridge simulators. We received very positive feedback from the participants in the course.

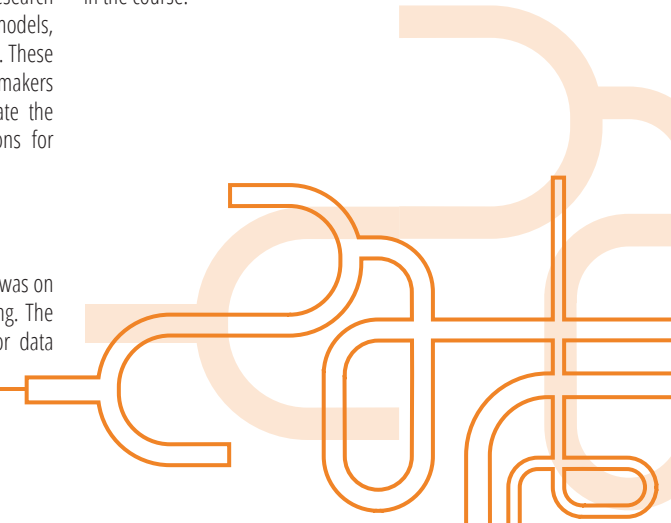

Highlights of scientific results

Ocean mining

Ocean mining

An analytical model based on modal analysis was developed for evaluating the structural response for a vertical ocean mining riser due to the density waves that may occur during the hydraulic lift operation.

This was followed by developing a prototype numerical model for evaluating the non-linear ocean mining riser dynamics in time domain considering a full two way coupling between the internal two or three phase flow and the external loads, the latter also including Vortex Induced Vibration related loads. The prototype model developed as part of the project is still beyond state of the art in 2023.

The work resulted in 3 conference papers, 4 conference presentations and 1 journal paper. In addition, 3 conference and 12 journal papers were associated to the project.

On-board decision support system (ODSS) architecture

A specification forming the basis for possible future developments of industrial ODSS systems based on the proofs of concept developed and presented at the SFI MOVE conferences has been produced as a documentation of the developed ODSS concept. This specification has been accompanied by case studies that demonstrate and validate the flexibility and robustness of the approach and designs.

Data driven ship model tuning methodology

Based on spectral values of measured waves and ship motions on an operating vessel, the parameters of the theoretical ship model are adjusted to match the response of the theoretical model to the measured response of the operating vessel. The tuning methodology has been tested on high-precision data from basin model tests in 1-D waves, in addition to full-scale 2-D wave spectral data and vessel motion data from the offshore support vessel Normand Vision (Havfram AS) and the smaller research vessel Gunnerus (NTNU).

Vessel shielding effects

Functional specification of method for taking into account shielding effects from an installation vessel on a lifted object has been developed. Numerical implementation and demonstration of the method for a relevant case has been performed and documented.

Hydrodynamic coefficients for subsea structures

To assist the project engineers designing and analysing marine operations on a daily basis, hydrodynamic coefficients for subsea structures and structure parts relevant for subsea lifting and installation operations have been collected from SINTEF Ocean's historic model test activity and made available for the SFI MOVE partners.

To gain more knowledge of the nature of the hydrodynamic forces on the structures, a comprehensive series of model tests establishing hydrodynamic coefficients for generalized subsea structures and structure parts has been performed. These model test results give valuable knowledge on how to use available data and estimate hydrodynamic coefficients for use in analysis of installation operations.

Guide on numerical modelling and simulation of offshore lifting operations

A modelling guide based on SINTEF Ocean's historical experience in numerical modelling of marine lifting operations, supplemented with the knowledge obtained on hydrodynamic coefficients, has been delivered.

Splash zone hydrodynamics

Model test data and commercial numerical codes have been used to come up with estimates of hydrodynamic coefficients in water entry phase of elements of subsea modules such as hatch covers, mudmats and their combination with other elements. Focus has been on estimation of slamming load and coefficients as well as damping and added mass coefficients at small submergence. Time domain simulations have been performed and compared with model test data and

measurements to assess the accuracy of the estimated coefficients.

Parametric seakeeping optimization tool

SFI MOVE researchers have developed a tool for holistic ship design optimization, enabling ship designers to optimize ship motion characteristics and thus seakeeping performance for defined operational tasks and sea areas by performing a parametric variation of the main vessel particulars as well as loading condition parameters. The focus of the development has been on a fast and easy to use tool which makes use of existing seakeeping codes, and the tool has been delivered as part of the ShipX/SIMA workbench. In an on-board decision support setting, the tool can be used to find the optimal loading condition for the ship for performing the intended operation in the forecasted weather.

Remote operations and dispersed teams

Finn Tore Holmeset contributed to installing sensors and transferring sensor data from the research vessel Gunnerus to NTNU's remote operation centre in Ålesund, which made the real-time testing of the simulator experiments possible. Bjarne Pareliussen, Frøy Birte Bjørneseth and Marie Haugli-Sandvik developed simulator scenarios for testing of the remote operation centre and the digital twin of R/V Gunnerus. These experiments provide the

foundation for further development of scenarios to test how onshore and offshore crew can develop a distributed situational awareness in complex marine operations. Marie Haugli-Sandvik was one of the initiators and developers of a maritime cyber security course with scenarios for cyber security training in maritime bridge simulators, providing the groundwork for future courses within this topic.

Offshore wind installations

Installation of offshore wind is normally carried out with a jack-up ship and with high-lift cranes lifting the individual parts of the offshore wind turbine into place one by one – in total, 5 individual lifting operations. The crane tip is higher than the objects to be lifted. Wind power fields are moving further from shore, tapping better quality wind resources, and pushing up capacity factors. Offshore wind turbines are becoming giants. Siemens Gamesa's massive 14 MW turbines produced their first electricity in 2021. The Siemens turbine has a rotor diameter of 222 metres and is 260 metres high to the rotor centre. Even bigger turbines at 20 MW are in development. Next-generation giant turbines demand new methods for installation, service, and repair. SFI MOVE has suggested a "low lifting mechanism". The tower, nacelle, and blades are lifted on the floating part in one single operation. The heavy lifting is done with a low crane and wires attaching the lower part of the tower. The lifted unit is balanced by additional wires at a higher point on the tower.



Assembly of offshore wind turbines using a low lifting mechanism compared to traditional lifting technology.

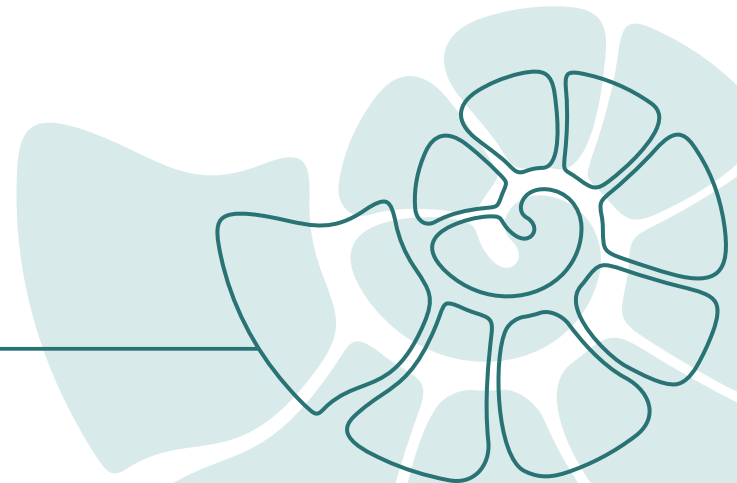

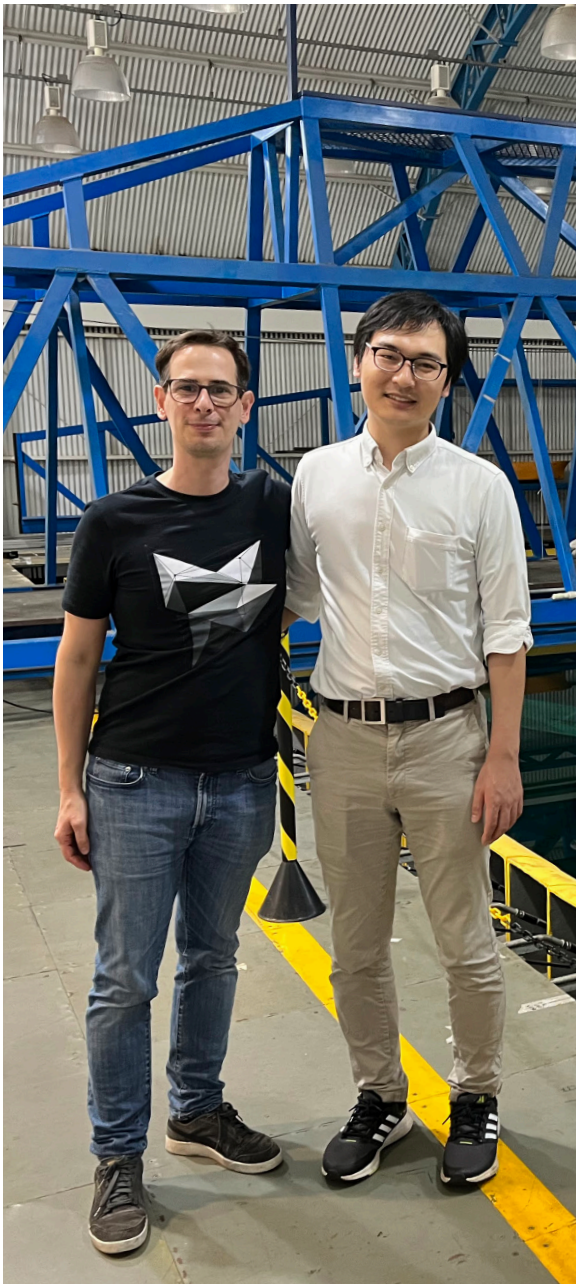

International cooperation
Text: Hans Petter Hildre



The MOVE Centre has a strategic cooperation with the University of Sao Paulo (USP) in Brazil. The key person in contact is Professor Kazuo Nishimoto. USP is combining marine research and nautical operations and has a similar approach to the one we have defined in SFI MOVE.

A cooperation agreement was signed in 2016; see Photo 1. Researchers had several mutual visits during the project period and student exchanges.

Within the offshore wind area, MOVE has been collaborating with the Department of Wind Energy (now Wind and Energy Systems) at the Technical University of Denmark (DTU). They are very strong in onshore and offshore wind energy research and engineering, in numerical analysis and experimental testing of wind turbine systems and wind turbine blades. The MOVE Centre also has a strategic cooperation with University College London (UCL). The Department of Ocean Operations and Civil Engineering has also been cooperating with Massachusetts Institute of Technology (MIT) within innovation and entrepreneurship.



Photo 1. Signing research cooperation at USP in 2016. The photo shows signing of the cooperation agreement with the Dean, Gunnar Bovim and the Minister of Education, Torbjørn Røe Isaksen.



Training of
researchers

Text: Hans Petter Hildre





Master's degree students from the Department of Ocean Operations and Civil Engineering in Ålesund and the Department of Marine Technology in Trondheim have been involved in the SFI centre's activities. In total 119 master's theses as a part of SFI MOVE and several new courses have been developed.

All PhD students have been invited to participate in the NTNU School of Innovation's programme for PhD students..

Employment of PhD candidates (number)							
By centre company	By other companies	By public organization	By university	By research institute	Outside Norway	Other	Total
1	2	1	3	1	5	1	14



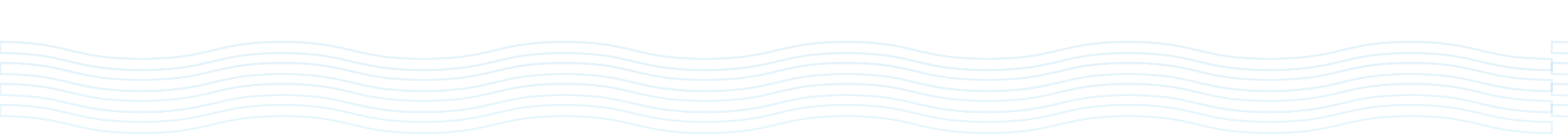

DISSEMINATION

Dissemination
of knowledge

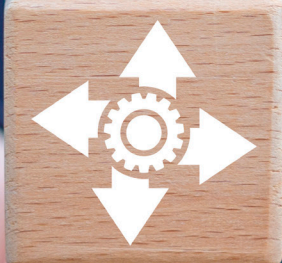
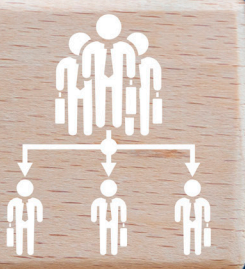

Annual reports

SFI MOVE has written comprehensive annual reports. They can be downloaded from the SFI MOVE homepage.

Conferences and workshop

SFI MOVE has arranged a conference for all partners twice a year. The spring conference focused on discussion and feedback on ongoing projects. These conferences have been combined with workshops about key topics in SFI MOVE. The autumn conference focused on project results and planning of next year's project activities.

Between 60–80 people have attended each conference. The conferences took place online during the Covid period.

PhD

SFI MOVE had 14 PhD students (including associated PhD students) and 9 postdocs. The PhDs are listed below. See Appendix 2 for details.



PhD candidates who have completed with financial support from the centre budget

Name	Thesis title
Fredrik Mentzoni	Hydrodynamic Loads on Complex Structures in the Wave Zone
Zhengru Ren	Advanced Control Algorithms to Support Automated Offshore Wind Turbine Installation
Amrit Shankar Verma	Modelling, Analysis and Response-Based Operability Assessment of Offshore Wind Turbine Blade Installation with Emphasis on Impact Damages
Robert Skulstad	Data-Based Modelling of Ships for Motion Prediction and Control Allocation
Xu Han	Onboard Tuning and Uncertainty Estimation of Vessel Seakeeping Model Parameters
Marie Haugli-Sandvik	Cyber Risk Perception in Offshore Operations: An Exploratory Study of Deck Officers' Perceptions of Cyber Risks in Norwegian Shipping Companies

PhD candidates who have completed with other financial support, but associated with the centre

Name	Thesis title
Svenn Are Tuttøren Værnø	Transient Performance in Dynamic Positioning of Ships; Investigation of Residual Load Models and Control Methods for Effective Compensation
Senthuran Ravinthrakumar	Numerical and Experimental Studies of Resonant Flow in Moonpools in Operational Conditions
Øyvind Rabliås	Numerical and Experimental Studies of Maneuvering in Regular and Irregular Waves
Tore Relling	A systems perspective on maritime autonomy. The Vessel Traffic Service's contribution to safe coexistence between autonomous and conventional vessels
Rami Zghyer	The Role of Ship Simulators and Maneuvering Models in Maritime Operations
Raheleh Kari	Exploring EEG Based Stress in Remote Ship Operations as Foundation of Customized Training
Bjarne Pareliusson	Maritime organizations facing a new era -Servitization, technology implementation and professional work
Mengning Wu	Uncertainty of Machine Learning-Based Methods for Wave Forecast and its Effect on Installation of Offshore Wind Turbines

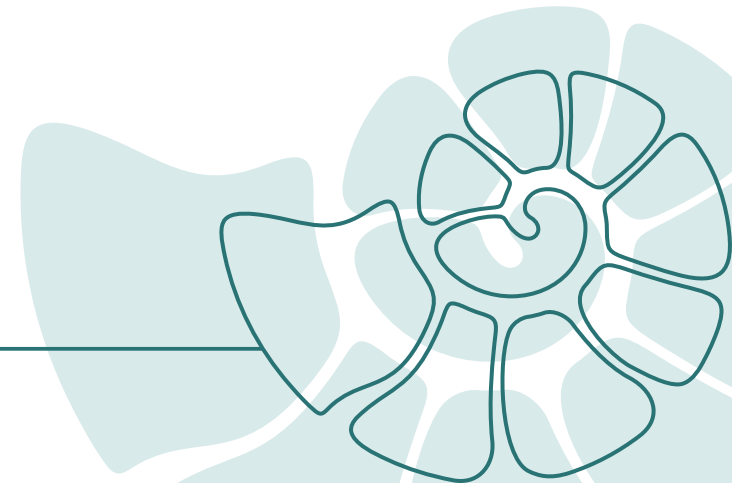

Research reports

Reports developed as part of SFI MOVE are stored at <https://www.ntnu.edu/move> and available to all SFI MOVE partners. In particular, the reports for hydrodynamic coefficients for subsea structures deserve special mention.

Software

Software developed as a part of SFI MOVE is stored at <https://www.ntnu.edu/move> and available for all SFI MOVE partners. We would particularly like to mention our software for data driven model tuning, vessel shielding effects, short-term predictions and on-board decision support system architecture, splash zone hydrodynamics, and parametric seakeeping optimization tool.

Publication (key numbers)

278 journal papers, conference papers and other publications are among the outputs from SFI MOVE. See Appendix 3 for a list of publications.

Arena and simulation centre for marine operations

The vision of establishing a leading research and innovation centre for demanding marine operations was a key statement defined at the beginning of the SFI MOVE project. A central element of this vision was to establish an “arena for research and industrial cooperation within demanding marine operations”. Establishment of a leading research and innovation centre for demanding marine operations was further detailed in the plan for the second period.

SFI MOVE has established a centre at NTNU in Ålesund. The centre has key technology for virtual prototyping of marine operation and has been important for full-scale testing. Digital twin technology has been tested for the NTNU research vessel Gunnerus. The idea of moving the simulations closer to the operations has been tested and trade-off simulations in case of changed weather conditions have been tested.



Complete list of research reports for SFI MOVE 2023

Lars T. Kyllingstad, Stian Skjong, Jarle Ladstein, Joakim Haugen; AMADEA – Adaptable Maritime Decision Support Architecture. SINTEF Ocean report 2023:00409, Trondheim, 2023-03-28

Frøydis Solaas;
SFI-MOVE – Hydrodynamic data for Olympic Challenger, WAMIT calculations
SINTEF Ocean report OC2023 F-036, 2023-05-03

Frøydis Solaas;
SFI-MOVE RA2 – WP6 - Guide on numerical modelling and simulation of installation of subsea structures
SINTEF Ocean report OC2023 F-031, 2023-05-16

Karl E. Kaasen;
Time-domain Modelling of Amplitude and Frequency Dependent Added Mass and Damping
SINTEF Ocean report OC2023 F-032, 2023-05-15

Karl E. Kaasen;
Preparation of Vessel Motion Data and Wave Spectra from OSV Normand Vision for Tuning of Numeric Vessel Model
SINTEF Ocean report OC2023 F-039, 2023-07-03

Reza Firoozkoobi
Experimental and Numerical Study of a Suction Anchor in Free Surface Zone
SINTEF Ocean report OC2023 F-037, 2023-07-13

Frøydis Solaas;
SFI-MOVE RA2 – WP6 Case study, Numerically modelling in SIMA of a suction anchor during splash zone crossing
SINTEF Ocean report OC2023 F-025, 2023-05-02

Robert Skulstad, Peihua Han, Tongtong Wang;
Experimental Results from R/V Gunnerus in November 2023
NTNU report, January 2024

2022

Solaas, Frøydis;
Hydrodynamic coefficients for subsea structures. Use of the Semi-analytical method for estimation of hydrodynamic coefficients for perforated plates – comparison with model test results. SINTEF Ocean report OC2022 F-052, Trondheim, 2022-05-24.

Solaas, Frøydis;
Hydrodynamic data for RV Gunnerus. VERES and WAMIT calculations. SINTEF Ocean report OC2022 F-094, Trondheim, 2022-09-26.

Solaas, Frøydis;
MARINE OPERATIONS
Case Study on shielding effects. Johan Sverdrup ITS installation 26 Mars 2017
SINTEF Ocean report OC2022 F-082, Trondheim, 2022-09-26.

2021

Solaas, Frøydis;
Hydrodynamic coefficients for subsea structures – Model tests of generalized structures. Part 5: Effect of vertical distance between protection roof and mudmat. SINTEF Ocean report OC2021 F-015, Trondheim, 2021-04-15.

Solaas, Frøydis;
Hydrodynamic coefficients for subsea structures – Model tests of generalized structures. Part 6: Importance of structure parts and effect of content inside the modules. SINTEF Ocean report OC2021 F-016, Trondheim, 2021-09-10.

Firoozkoobi, Reza;
Splash zone hydrodynamics. Estimation of slamming coefficients of subsea hatch covers during water entry. SINTEF Ocean report OC2021 F-118, Trondheim, 2022-02-08.

2020

Kaasen, Karl Erik;
Wave measurement with radar. Survey of existing systems and recommendation. SINTEF Ocean report OC2020 F-092, Trondheim, 2020-07-30.

Solaas, Frøydis;
Hydrodynamic coefficients for subsea structures – Model tests of generalized structures. Part 3: Added mass and damping at different submergences. SINTEF Ocean report OC2020 F-112, Trondheim, 2020-09-21.

Solaas, Frøydis;
Hydrodynamic coefficients for subsea structures – Model tests of generalized structures. Part 4: Forces in regular waves versus oscillation tests. SINTEF Ocean report OC2020 F-119, Trondheim, 2020-10-19.

Solaas, Frøydis;
Splash zone hydrodynamics. Use of a Morison element model to estimate forces on conventionalized subsea structures in the wave zone. SINTEF Ocean report OC2020 F-139, Trondheim, 2020-11-24.

Rogne, Øyvind Ygre;
Wave kinematics with radiation-diffraction effect in non-stationary marine operation analysis. Pre-study and recommendation for new implementation. SINTEF Ocean report OC2020 F-140, Trondheim, 2020-11-26.

Kaasen, Karl Erik;
Vessel Model Tuning with Spectral Wave Measurement. SINTEF Ocean report OC2020 F-150, Trondheim, 2020-12-14.

Firoozkoobi, Reza;
Splash zone hydrodynamics. Summary of studies on splash zone hydrodynamics in SFI MOVE. SINTEF Ocean report OC2020 F-138, Trondheim, 2020-12-17.

2019

Kaasen, Karl Erik;
Automatic Estimation of Parameters in Numerical Vessel Models from Laboratory Tests. SINTEF Ocean report OC2019 F-030, Trondheim, 2019-02-15.

Sandvik, Peter Christian; Levold, Pål;
Lifting operation analysis. New tugger winch model in SIMO/SIMA. SINTEF Ocean report OC2019 F-067, Trondheim, 2019-08-14.

Solaas, Frøydis;
Hydrodynamic coefficients for subsea structures – Model tests of generalized structures. Part 1: Test setup, model description and overview of test program. SINTEF Ocean report OC2019 F-118, Trondheim, 2019-11-05.

Solaas, Frøydis;
Hydrodynamic coefficients for subsea structures – Model tests of generalized structures. Part 2: Added mass and damping for generalized mudmat models. SINTEF Ocean report OC2019 F-137, Trondheim, 2019-11-20.

Solaas, Frøydis;
Numerical modelling of installation operations. SINTEF Ocean report OC2019 F-048, Trondheim, 2019-12-10.

Kaasen, Karl Erik;
Tuning of Vessel Model: A Preliminary Simulation Study. SINTEF Ocean report OC2019 F-193, Trondheim, 2019-12-23.

2018

Solaas, Frøydis;
Hydrodynamic coefficients for subsea structures. A collection of hydrodynamic data for structures close to the surface or bottom. SINTEF Ocean report OC2018 F-091, Trondheim, 2011-11-13.

Gutsch, Martin;
Weighting of Performance Indicators for Offshore Lifting Operations. SINTEF Ocean report OC2018 I-118, Trondheim, 2018-12-18.

2017

Solaas, Frøydis; Jin, Jingzhe; Sandvik, Peter Christian;
Case study. Numerical analysis of Johan Sverdrup ITS installation by use of SIMO/SIMA. SINTEF Ocean report OC2017 F-172, Trondheim, 2017-11-09.

Solaas, Frøydis; Sandvik, Peter Christian;
Hydrodynamic coefficients for subsea structures. A collection of Hydrodynamic data for complete structures. SINTEF Ocean report OC2017 F-235, Trondheim, 2017-12-19.

2016

Solaas, Frøydis;
Hydrodynamic coefficients for subsea structures. A collection of Hydrodynamic data for structure parts. SINTEF Ocean report MT2016 F-156, Trondheim, 2017-01-11.

Background Reports

Kaasen, Karl Erik;
Automatic Estimation of Parameters in Numerical Vessel Models from Laboratory Tests. SINTEF Ocean report OC2019 F-030, Trondheim, 2019-02-15.

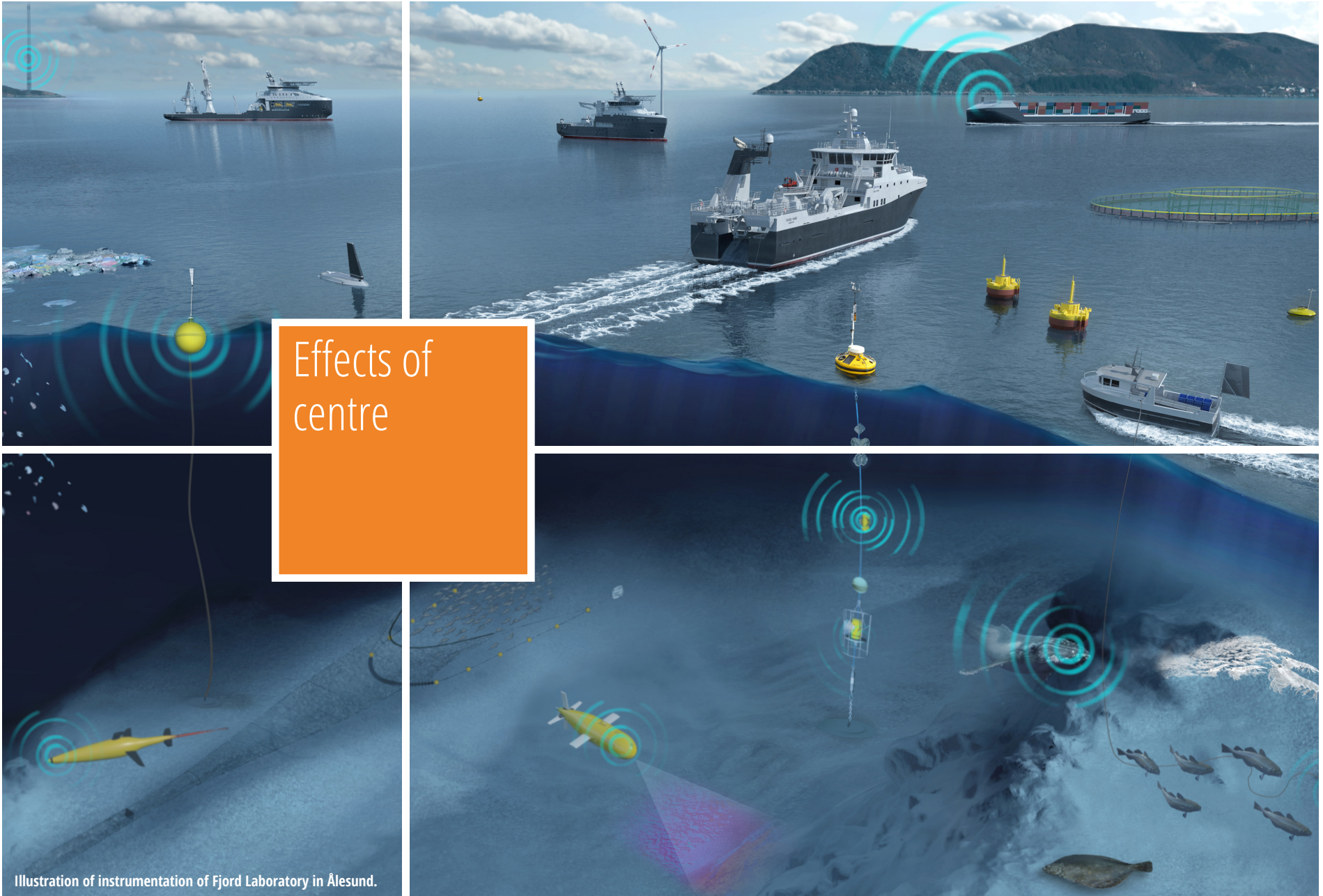

Effects of
centre

Illustration of instrumentation of Fjord Laboratory in Ålesund.

Norway is one of the world's largest maritime offshore nations and has been a major player for more than 150 years. Shipowners are especially active within shipping areas like offshore service vessels, fisheries, and aquaculture. Offshore wind service is a growing business in Norway, and major offshore wind developments in the North Sea is in planning. Marine operations are a common dimension in all these segments. SFI MOVE is a contribution to establish new methods, tools and facilities for marine operations and Norwegian maritime industry.

SINTEF Ocean conducts research and innovation related to ocean space. Our ambition is to continue Norway's leading position in marine technology and biomarine research. Many of the challenges of modern society can be solved through sustainable use of the ocean. SINTEF Ocean has extensive expertise in the field of hydrodynamics and cybernetics, which have been key areas of focus in SFI MOVE. Participation in major research centres such as MOVE is crucial to our strategy and activity related to marine operations and fits well with SINTEF's vision "Technology for a Better Society". SINTEF Ocean has conducted research on ships and ocean structures for more than 80 years. The MOVE project has given us the opportunity to expand our collaboration with NTNU and attract new generations of talents within marine technology.

The Norwegian Ocean Technology Centre with new laboratories and infrastructure is now being built. This centre will develop new knowledge and technology with the ocean being the common denominator and will consist of new laboratories at Tyholt in Trondheim, combined with installations in Trondheimsfjorden and in the sea off the coast of Hitra, Frøya and Ålesund. In SFI MOVE, SINTEF Ocean – in partnership with academia and industry – has developed new knowledge for numerical analysis, experimental techniques, and utilization of full-scale sea trials. Today, SINTEF Ocean is well positioned within various segments of the ocean industries.

The Norwegian Ocean Technology Centre will have the following laboratories:

- The Ocean Basin Laboratory
- Seakeeping and Manoeuvring Basin
- Machinery Laboratory
- The Marine Structures Laboratory
- Student Laboratories
- The Fjord Laboratory

The Norwegian Ocean Technology Centre includes Fjord Laboratory, which consists of several facilities with advanced research equipment and sensors that are in Trondheimsfjorden, and off the coast of Hitra/Frøya, and Ålesund.

The laboratories give researchers and businesses the opportunity to test new solutions in model trials before they are tested on a full scale and are necessary to reduce the risk before the solutions are put into use. Computer simulation is also an important part of the centre's operations. Through the interaction with physical experiments, various digital simulation models are validated and improved.

- Subsea robots and subsea infrastructure
- Autonomous ship and ship operations
- Aquaculture
- Marine observatory and environmental research
- Ship operations research
- Digitalization in the ocean space: models, monitoring, simulations, integration of sensor and communication platforms
- Ocean energy: wind and wave energy

Through the R&D collaboration in SFI MOVE, SINTEF Ocean, together with the partners, has created innovative cooperative teams and spin-off projects. For instance, the knowledge and methods developed in on-board decision support systems will be built on and continued in the NorthWIND Centre for Environment-friendly Energy Research (FME) for the application of gangway operations for offshore wind service operations vessels. The long-term



Fjordlab



Maskinlaboratoriet



Havbassenget



Sjøbassenget

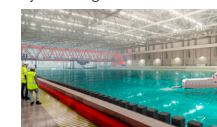

Kavitasjonslaboratoriet



Studentlaboratoriene



Konstruksjonslaboratoriet



Kontor og undervisning



effort of SFI MOVE also allowed us to execute strategic and targeted development of new numerical methods that have significantly improved our state-of-the-art software, SIMO. Tools for data driven model tuning, vessel shielding effects, short-term prediction, and splash zone hydrodynamics have been developed and tested. Co-simulation capabilities have been tested. A parametric seakeeping optimization tool has also been developed. The on-board decision support system architecture may be a next-generation tool used in real time during operation.

SFI MOVE has established a centre, Arena, at NTNU in Ålesund. The centre has key technology for virtual prototyping of marine operations and has been important for full-scale testing. Digital twin technology has been tested for the NTNU research vessel Gunnerus. The idea of moving the simulations closer to the operations has been tested and trade-of simulations in case of changed weather conditions have been tested.





Future prospects

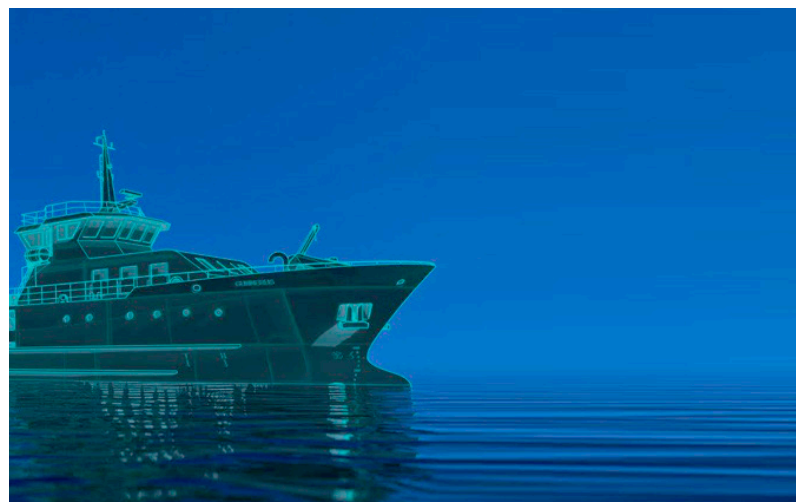

Hans Petter Hildre,
NTNU

The overall objective for SFI MOVE is to facilitate marine operations in a commercial and cost-efficient manner, thereby contributing to positioning the Norwegian maritime industry towards the market of such operations worldwide. As operations become more extensive, there is a growing need for all-year marine operations. This need will significantly impact technology, operational procedures, and costs, and will require very different solutions depending on the environment in which you are operative.

Marine operations are designed, simulated, and planned long before the operation is carried out. Parameters are assumed for the type of vessel, load condition, wind, waves, lifted objects' behaviour in air and sea, etc.. The simulation results show that the operation can be carried out if a given sea state is not exceeded. Therefore, simulations are based on a series of assumptions and uncertainties. Significant safety margins are needed to compensate for these uncertainties. How can we reduce this uncertainty and then reduce Waiting on Weather (WoW)?

In SFI MOVE, we have been working on reducing Waiting on Weather by bringing the analyses close to the operations. I think on-board simulations will be the next step in simulation of marine operations: Real-time simulations considering real met-ocean and ship conditions. Short- (0-2 minutes), medium- (hours) and long-term (more than 72 hours) predictions of met-ocean, ship responses as well as in parameters limiting the marine operations. Digital twins are the next step in simulation technology allowing real-time input from sensors into the simulation algorithms.



Karl Henning Hasle
NTNU

The installation process both for fixed and floating wind turbines have involved challenging and complex dynamic problems with a high degree of interdisciplinary achievements (nonlinear hydrodynamics, complex multibody dynamics, and advanced control strategies of hydraulically driven winches).

The interdisciplinary problem has motivated us to take advantage of a co-simulation approach where the different parts of the complex dynamic problem are modelled with high fidelity in separate domain calculations (following the idea of Functional Mock-up Units (FMUs), and then information is shared between all the units through a Functional Mock-up Interface (FMI). This is a very promising approach that not only enables high fidelity simulations in separate domains and shares only the essential information between the different units, but also allows for proprietary information to be kept within a black box if a vendor wishes to conceal the technology's secrets.

The work and cooperation have been truly fascinating and has sparked considerable attention also internationally. We have been invited to talk about the work to conferences abroad (e.g. IMCA lifting and rigging seminar) and invited to join an international forum for developing a sustainable blue economy towards carbon neutrality.



Egil Giertsen,
SINTEF Ocean

A lot of good work has been done on a wide range of research topics as part of SFI MOVE. The work on collecting, establishing, and documenting hydrodynamic coefficients for different structures and structural components is one example that is believed to have great value for the industry from day one. Furthermore, on the topic of development of new numerical models and analysis procedures, I think the work on shielding effects, splash zone hydrodynamics and tuning of vessel models should be mentioned. A significant effort has also been invested in developing efficient and robust methods for on-board data collection and distribution. That said, within the "On-board Decision Support System (ODSS)" topic, there is still a lot of work to be done to fulfil the vision. If you pass unphysical data to a numerical model, even the most robust model will fall over. Hence, in an ODSS setting, numerical robustness to unphysical data is key. Furthermore, computational speed is also important; you lose if your ODSS solution means that the marine operation needs to wait for the calculations/requires the marine operation to wait for the calculations. Traditionally, to avoid passing unphysical data to the computations, raw data is typically carefully filtered in advance before passing it to the processing chain. This filtering process also takes time, of course. In the world we live in, with all its artificial intelligence (AI) and machine learning (ML), maybe it is time to think differently when developing numerical models for real-time analysis applied to live data? If the numerical algorithms had a built-in ability to avoid trying to process unphysical data, to my mind that would be a good approach. And the algorithms must be faster than real-time, of course. Maybe next-generation ODSS's should be built based on numerical algorithms with inherent data awareness (DA) and data intelligence (DI). Just a thought as we now close out SFI MOVE.



Marie Haugli-Sandvik,
NTNU

The work we did within remote operations and dispersed teams provided use cases for real-time testing of our digital twin and remote operation centre. These use cases and simulator set-ups were developed in close collaboration with our industry partners and have provided insights into challenges and opportunities for utilizing such technological solutions within our industry.

The research activities have stimulated project ideas related to utilization of ROC and cyber security challenges related to remote operations. Amongst other things, we are planning for a project proposal related to how we can use remote operation centres and digital twin technology to enhance efficiency in the traditional shipping fleet.



Svein Sævik,
NTNU

As part of SFI MOVE, different techniques for ship hydrodynamic model updating based on monitored data was investigated in order to realize the concept of response-based marine operations. Part of this was the treatment of the ship model parameters as stochastic variables, applying discrete Bayesian updating to get a best possible fit to monitored data and the concept of applying surrogate models to speed up the model update computation.

These research activities inspired the Slender Structures Research Group at the Department of Marine Technology to apply for the Research Council of Norway project 308832 (PRAI: Predicting Riser-response by Artificial Intelligence) in cooperation with SINTEF Ocean and SINTEF Digital. The project is ongoing and focuses on investigating different alternative algorithms for model updating, hybrid modelling and uncertainty estimation for integrity management of riser systems.

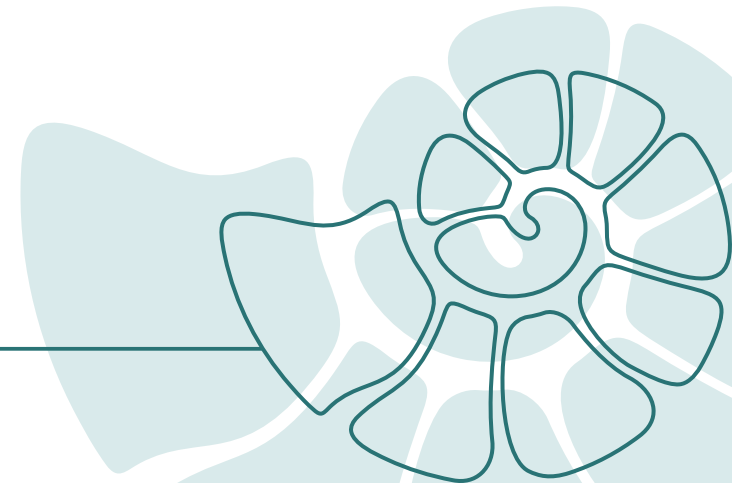



Conclusions

Text: Hans Petter Hildre



The success of SFI MOVE is a result of collaboration between research by NTNU and SINTEF and industrial partners. This collaboration includes PhD students, postdoctoral students and master's degree students.

The SFI centre model is working very well with respect to achieving cooperation between research partners. Ålesund University College was merged into NTNU in 2016 and organized as part of the Faculty of Engineering in 2017. SFI MOVE has played an important role in developing related research activities in Ålesund and cooperation with the Department of Marine Technology in Trondheim. SFI MOVE also played an active role in establishing SINTEF Ålesund in 2017. The Head of SINTEF Ålesund, Henning Borgen, was also the project leader in SFI MOVE.

A challenge in an 8-year project is to adapt to rapidly changing industrial needs. PhD work and research activities are processes that need several years to complete. It is therefore hard to change research strategy or cover short-term needs.

SFI MOVE made innovation plans in close collaboration with the industry and then developed these plans into one- and three-year plans. This approach worked well in the transition between period one and two in the project but did not work very well for shorter modifications. The set-up with PhDs linked to professors over 8 years also complicates the opportunities to adapt to changed industrial needs.

With research partners in several locations, regular communication and interactions were very important for the management. A tight management research group with weekly meeting was a key element to achieve common understanding and goals.

SFI MOVE will not apply for a new SFI project within marine operations. The focus in the years to come will be on implementation of research results, building practical tools and methods for the industry.



Photo: Børge Sandnes

Appendix 1 – Statement of accounts for the complete period of centre financing

Funding

All figures in 1000 NOK.

Activity/Item	RCN	Host Institution IHB/NTNU Ålesund	IMT/ NTNU Trondheim	Marintek	SINTEF	Equinor	Statkraft	EMAS-AMC	Havfram	Ustein International	VARD	NTNU Ocean Training	Cranemaster	Kongsberg Maritime	Farstad	Olympic	Havila	OSC	AKP/GCE-Blue Maritime	DNV	TechnipFMC	Subsea7	TOTAL	
2015:																								
WA1	376	-	128	223	-	200	100	-	39	53	58	57	59	66	57	16	64	64	64	69	-	-	-	1,693
WA2	180	-	328	244	-	200	100	-	59	74	82	81	82	93	81	27	94	94	92	78	-	-	-	1,989
WA3	37	-	-	-	249	-	-	-	-	-	-	-	-	-	-	-	-	-	-	-	-	-	-	286
WA4	257	70	-	-	-	120	35	-	-	-	22	22	22	25	22	17	17	17	4	13	-	-	-	663
Lab/Dissemination	411	-	-	-	-	200	100	-	-	-	-	-	-	-	-	-	-	-	-	-	-	-	-	711
Management	191	83	56	-	-	30	40	-	-	50	40	40	40	40	40	40	40	40	40	40	-	-	-	850
2016–2023:																								
Project 1	1 488	254	178	219	19	-	-	-	-	92	200	50	230	-	-	-	-	-	53	227	-	-	-	3 010
Project 2	7 634	3 037	3 711	1 128	893	750	750	396	74	-	286	300	91	288	376	677	886	400	350	462	-	-	-	22 489
Project 3	562	1 611	-	-	752	300	-	-	-	200	128	200	-	307	152	-	-	412	53	73	-	-	-	4 750
Project 4	5 046	6	177	-	10	-	-	-	-	16	-	-	-	-	-	-	-	-	177	43	-	-	-	5 475
Project 5	24 967	1 977	3 378	-	478	2 590	-	-	63	791	642	885	-	653	50	795	311	598	309	372	319	500	-	39 678
Project 6	27 211	3 561	6 861	-	6 975	2 119	-	-	163	744	1 142	878	-	1 116	200	1 021	1 138	866	109	811	735	567	-	56 217
Project 7	1 796	-	1 513	-	388	100	-	-	-	124	191	71	-	156	-	50	75	-	58	87	100	100	-	4 809
Project 8	1 573	5 459	-	-	-	200	-	-	29	333	228	467	-	356	-	578	779	413	-	415	150	137	-	11 117
Project 9	2 498	268	-	-	210	-	-	-	-	-	-	-	-	-	-	-	-	-	-	-	-	-	-	2 976
Lab/Dissemination	5 124	-	600	-	-	2 181	-	-	-	300	100	100	-	100	150	150	350	240	300	430	300	100	-	10 525
Management	10 721	-	-	-	-	200	-	-	-	200	-	-	-	-	-	-	-	100	200	100	-	-	-	11 521
Total	90 072	16 326	16 930	1 814	9 974	9 190	1 125	396	427	2 977	3 119	3 151	524	3 200	1 128	3 371	3 754	3 244	1 809	3 220	1 604	1 404	178 759	

Project 1: OW: Low Cost Installation and Maintenance of Fixed Offshore Wind Structures (2016)

Project 2: Subsea: Safe – All Year – Cost-efficient Subsea Operation (2016-2017)

Project 3: Simulation Technology and Virtual Prototyping as a Common Approach from Design to Operation (2016-2017)

Project 4: Seabed Mining: Exploration of Technologies to Develop Seabed Mining as a New Business Area (2016-2018)

Project 5: Innovative Installation of Offshore Wind Power Systems (2016-2023)

Project 6: On-board Decision Tool (2018-2023)

Project 7: Design for Workability (2018-2020)

Project 8: Remote Operations/Dispersed Teams (2018-2023)

Project 9: Full Scale Test Project (2023)

Cost

All figures in 1000 NOK.

Activity/Item	Host Institution NTNU / Ålesund	NTNU, Tr.heim	Marintek	SINTEF	Equinor	Statkraft	EMAS-AMC	Havfram	Ulstein International	VARD	NTNU Ocean Training	Cranemaster	Kongsberg Maritime	Farsstad	Olympic	Havila	OSC	AKP/GCE-Blue Maritime	DNV	Technip-FMC	Subsea7	TOTAL	
2015:																							
WA1	-	395	890	-	-	-	-	39	31	38	37	38	46	37	-	43	43	37	19	-	-	1 693	
WA2	-	399	977	-	-	-	-	59	46	57	56	58	69	56	-	64	64	56	28	-	-	1 989	
WA3	-	-	-	286	-	-	-	-	-	-	-	-	-	-	-	-	-	-	-	-	-	286	
WA4	600	-	-	-	-	-	-	-	-	7	7	7	9	7	-	8	8	7	3	-	-	663	
Lab/Dissemination	711	-	-	-	-	-	-	-	-	-	-	-	-	-	-	-	-	-	-	-	-	711	
Management	794	56	-	-	-	-	-	-	-	-	-	-	-	-	-	-	-	-	-	-	-	850	
2016–2023:																							
Project 1	859	1 341	539	19	-	-	-	-	92	-	50	30	-	-	-	-	-	53	27	-	-	3 010	
Project 2	3 930	7 316	4 373	4 385	-	-	396	74	-	86	300	90	288	276	277	486	-	150	62	-	-	22 489	
Project 3	1 902	-	158	1 865	-	-	-	-	-	128	-	-	107	52	-	-	412	53	73	-	-	4 750	
Project 4	24	5 305	-	10	-	-	-	-	16	-	-	-	-	-	-	-	-	77	43	-	-	5 475	
Project 5	18 407	15 411	320	1 880	-	-	-	63	461	322	285	-	323	-	695	311	338	309	159	207	187	39 678	
Project 6	6 803	17 756	-	27 429	-	-	-	163	374	462	478	-	486	-	371	388	466	109	204	448	280	56 217	
Project 7	-	2 543	-	1 554	-	-	-	-	124	191	71	-	56	-	50	75	-	58	87	-	-	4 809	
Project 8	8 472	-	-	-	-	-	-	29	233	227	268	-	216	-	378	779	313	-	115	50	37	11 117	
Project 9	2 366	-	-	610	-	-	-	-	-	-	-	-	-	-	-	-	-	-	-	-	-	2 976	
Lab/Dissemination	10 525	-	-	-	-	-	-	-	-	-	-	-	-	-	-	-	-	-	-	-	-	10 525	
Management	10 859	662	-	-	-	-	-	-	-	-	-	-	-	-	-	-	-	-	-	-	-	11 521	
Total	66 252	51 184	7 257	38 038	-	-	396	427	1 377	1 518	1 552	223	1 600	428	1 771	2 154	1 644	909	820	705	504	178 759	

Appendix 2 – List of Post-docs, Candidates for PhD and MSc degrees during the full period of the centre

Candidates for PhD and Post-docs 2015–2023

PhD candidates who have completed with financial support from the centre budget						
Name	M/F	Nationality	Scientific area	Years in the centre	Thesis title	Main thesis Advisor
Fredrik Mentzoni	M	Norwegian	Numerical models and tools	2015-2019	Hydrodynamic Loads on Complex Structures in the Wave Zone	Trygve Kristiansen
Zhengru Ren	M	Chinese	On-board systems	2016-2018	Advanced Control Algorithms to Support Automated Offshore Wind Turbine Installation	Roger Skjetne
Amrit Shankar Verma	M	Indian	Numerical models and tools	2016-2019	Modelling, Analysis and Response-Based Operability Assessment of Offshore Wind Turbine Blade Installation with Emphasis on Impact Damages	Zhen Gao
Robert Skulstad	M	Norwegian	Integrated simulator environment	2016-2020	Data-Based Modelling of Ships for Motion Prediction and Control Allocation	Houxiang Zhang
Xu Han	M	Chinese	On-board systems	2018-2021	Onboard Tuning and Uncertainty Estimation of Vessel Seakeeping Model Parameters	Bernt Leira
Marie Haugli-Sandvik	F	Norwegian	Integrated simulator environment	2019-2023	Cyber Risk Perception in Offshore Operations: An Exploratory Study of Deck Officers' Perceptions of Cyber Risks in Norwegian Shipping Companies	Frøy Birte Bjørneseth

PhD candidates who have completed with other financial support, but associated with the centre						
Name	M/F	Nationality	Scientific area	Years in the centre	Thesis title	Main thesis Advisor
Svenn Are Tuttoren Værnø	M	Norwegian	Numerical models and tools	2015-2017	Transient Performance in Dynamic Positioning of Ships: Investigation of Residual Load Models and Control Methods for Effective Compensation	Roger Skjetne
Senthuran Ravinthrakumar	M	Norwegian	Numerical models and tools	2016-2019	Numerical and Experimental Studies of Resonant Flow in Moonpools in Operational Conditions	Trygve Kristiansen
Øyvind Rabliås	M	Norwegian	Numerical models and tools	2017-2021	Numerical and Experimental Studies of Maneuvering in Regular and Irregular Waves	Trygve Kristiansen
Tore Relling	M	Norwegian	Integrated simulator environment	2017-2020	A systems perspective on maritime autonomy. The Vessel Traffic Service's contribution to safe coexistence between autonomous and conventional vessels	Hans Petter Hildre
Rami Zghyer	M	Jordanian	Integrated simulator environment	2017-2021	The Role of Ship Simulators and Maneuvering Models in Maritime Operations	Runar Ostnes
Rahelah Kari	F	Iranian	Integrated simulator environment	2018-2021	Exploring EEG Based Stress in Remote Ship Operations as Foundation of Customized Training	Henrique Gaspar
Bjarne Pareliusson	M	Norwegian	Integrated simulator environment	2019-2022	Maritime organizations facing a new era -Servitization, technology implementation and professional work	Marte Fanneløb Giskeødegård
Mengning Wu	F	Chinese	Numerical models and tools?	2020-2021	Uncertainty of Machine Learning-Based Methods for Wave Forecast and its Effect on Installation of Offshore Wind Turbines	Zhen Gao

PhD students with financial support from the centre budget who still are in the process of finishing studies						
Name	M/F	Nationality	Scientific area	Years in the centre	Thesis title	Main thesis Advisor
Martin Friedwart Gutsch	M	German	Vessel performance	2015-2020	Performance Indicators for vessel performance for challenging marine operations	Sverre Steen
Maël Moreau	M	French	Numerical models and tools	2017-2020	Hydrodynamic study of roll motion of offshore vessels in operation	Trygve Kristiansen
Jiafeng Xu	M	Chinese	Integrated simulator environment	2015-2018	Real-time Simulation of Marine Operations	Karl Henning Halse
Behfar Ataei	M	Iranian	Integrated simulator environment	2019-2022	Virtual Prototyping of Installation of Offshore Power Systems	Karl Henning Halse
Gowtham Radhakrishnan	M	Indian	Numerical models and tools	2019-2022	Onboard decision support systems based on mathematical and data-driven models for predicting vessel response during marine operations in realistic conditions	Bernt Johan Leira
Sunghun Hong	M	South Korean	Integrated simulator environment	2020-2023	Global dynamic analysis of on-site offshore installation of floating offshore wind turbines	Karl Henning Halse

Appendix 2 – List of Post-docs, Candidates for PhD and MSc degrees during the full period of the centre

Postdoctoral researchers with financial support from the centre budget

Name	M/F	Nationality	Scientific area	Years in the centre	Scientific topic	Main contact
Mia Abrahamsen-Prsic	F	Croatian	Numerical models and tools	2016-2019	Hydrodynamic loads on submerged complex structures under the influence of waves and currents	Trygve Kristiansen
Zhiyu Jiang	M	Chinese	Numerical models and tools	2016-2018	Efficient and accurate numerical methods and models for dynamic response analysis for installation of offshore wind turbines	Zhen Gao
Mats Jørgen Thorsen	M	Norwegian	Numerical models and tools	2016-2018	Coupled dynamic analysis of subsea mining riser systems	Svein Sævik
Niranjn Reddy Challabotla	M	Indian	Numerical models and tools	2016-2018	Coupled dynamic analysis of subsea mining riser systems	Ole Jørgen Nydal
Zhengru Ren	M	Chinese	On-board systems	2019-2021	Onboard decision support system	Roger Skjetne
Ting Liu	F	Chinese	Integrated simulator environment	2020-2022	Optimization of low-height lifting system for installation of offshore wind turbines (OWT) by using floating vessel	Karl Henning Halse
Mohammad Mahdi Abaei	M	Iranian	On-board systems	2021	A Data-Driven Approach for Evaluating Safety of Offshore Installation in Splash Zone	Bernt Johan Leira
Robert Skulstad	M	Norwegian	Integrated simulator environment	2021-2023	Hybrid modelling for ship motion prediction	Karl Henning Halse
Rafael Salles	M	Brazilian	On-board systems	2022-2023	"Reliable online predictions on lift marine operations, considering installed object failure modes and inherent uncertainties"	Bernt Johan Leira
George Jagite	M	Romanian	Numerical models and tools	2022-2023	Short-term deterministic forecasting of waves fields	Zhen Gao

Postdoctoral researchers working on projects in the centre with financial support from other sources

Name	M/F	Nationality	Scientific area	Years in the centre	Scientific topic	Main contact
Shuai Yuan	M	Chinese	Integrated simulator environment	2020-2021	Dynamic Power Cable Installation Optimization for Floating Offshore Wind Farms Based on Co-simulation	Houxiang Zhang

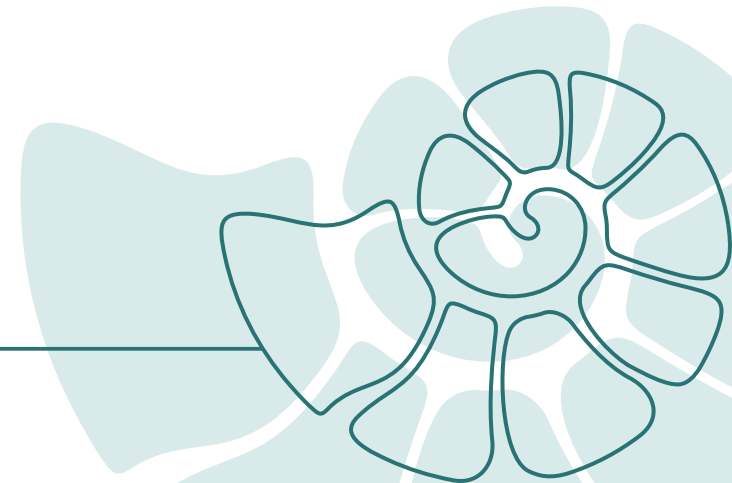

Master's degrees 2015–2023

2015	Name	Sex M/F	Topic
	Fredrik Rødne Jenssen	M	Dynamic Analysis of ROV Operation
	Ying Wei	F	Anchor loads on pipelines
2016	Name	Sex M/F	Topic
	Simon Holm Hemstad	M	Power and energy optimization for marine operations
	Zafer Zortul	M	Investigation of sloshing through experiments and modeling with mechanical equivalent models
	Junjie Ding	M	Parametric mechanical design for system integration and simulation of virtual crane
	Dahai He	M	Virtual winch prototyping - Active/passive heave compensation system in 2D Sim
	Yu Li	M	Component model development and management oriented to both system performance testing and operational behaviour simulation
	Bingqiang Wang	F	Modelling and simulation of accumulator systems for heave compensated winches in cranes AGX
	Zhongkai Wang	M	HIL simulation of hydraulic crane control
	Kjell Lennart Nygård	M	Effect of anchor cable tension on an AHTS vessel at sea.
	Petter Svardal Langeland	M	Modelling of anchor lines, resulting tension on AHTS (Aquasim)
	Zhaonan Zhong	M	Smoothed particle hydrodynamics calculations
	Sthefano Lande Andrade	M	Optimal Structural configuration for Ulstein PX
	Greta Levisauskaite	F	Implementation of GD framework in ship design for improving exchange and minimizing 3D remodelling
	Ruta Mastekaite	F	Product lifecycle management applied to offshore support vessels
	Brigita Matulaityte	F	Shell product concept applied to ship design
	Thiago Gabriel Monteiro	M	A knowledge-based approach for an open object-oriented toolbox in ship design
	Tian Xu	M	Intelligent library in ship design
	Georgiana Chelmu	F	Framework for product configurator deployment
	Simen Haddal Sæther	M	Study of vibration control and analysis on ships
	Arne Solevåg	M	Ship response and manoeuvrability - Main Machinery characteristics, configuration modes, and its resulting effect on thrust response
	Jon Bjørnø	M	Thruster-assisted position mooring of C/S Inocean Cat I Drillship
	Preben Frederich	M	Constrained Optimal Thrust Allocation for C/S Inocean Cat I Drillship
	Evgenii Koloshkin	M	Torsion Buckling of Dynamic Flexible Risers
	Jens Mjøen Hafstad	M	Numerical investigation of collapse and ductile fracture in X65 offshore pipelines subject to external pressure, bending and axial loads (cooperation with the Federal University of Rio de Janeiro)
	Martine Gripp Bay	M	Assessment of Marine Riser Joints During Offshore Drilling Operation (cooperation with Bureau Veritas Paris)
	Marius Maastad	M	Numerical and Experimental Study of the Fred Olsen Wind Turbine Concept
	Fride Midtbø Birkeland	F	Numerical Simulation of Installation of XL Monopile for Offshore Wind Turbines
	Shi Deng	M	Numerical Simulations for Lift-off Operation of an Offshore Wind Turbine Monopile
	Dapeng Xu	M	Numerical Modelling and Simulations for Lowering of an Offshore Wind Turbine Tripod
	Nishat Al Nahian	M	Structural Analysis of the Gripper Connection during Monopile Installation
	Efstathios Tsigkris	M	Dynamic Response Analysis of a Spar Floating Wind Turbine in Level Ice with Varying Thickness

Appendix 2 – List of Post-docs, Candidates for PhD and MSc degrees during the full period of the centre

2017	Name	Sex M/F	Topic
	Aurelien Lorenzo Edy	M	Time domain simulations of wind turbine blade installation using a floating installation vessel
	Rui Xu	M	Stress analysis of a monopile foundation under the hammering loads
	Muhammad Abu Zafar	M	Design and analysis of a semi-submersible vertical axis wind turbine
	Sevyllen Kistnen Appiah	M	Analysis of the parametric instability of the STC combined wind and wave energy concept
	Xiao Liu	F	Numerical modelling and simulation of floating oil storage tanks considering the sloshing effect
	Tobias Borgenhov	M	Vessel roll. Investigation of roll damping on an FPSO with sponsons and bilge keels
	Prabhu Bernard	M	Installation of Offshore Wind Turbin on Floating Foundation using NX
	Thor Erling Tangen	M	Towing tank: Mechanical design, hydrodynamical resistance testing and verification
	Yu Feilong	M	Gangway control system
	Siren Therese Thorsen	F	Time domain versus frequency domain VIV modelling with respect to fatigue of a deep water riser
	Weitan Zhou	M	Optimization of passive heave compensation during Subsea Factory heavy lift operations
	Silje Aarvik Johannessen	F	Autonomous heading control in position mooring with thruster assist
	Alexander Mykland	M	Low-Cost Observer and Path-Following Adaptive Autopilot for Ships
	Guttorm Udjus	M	Force Field Identification and Positioning Control of an Autonomous Vessel using Inertial Measurement Units
	Mats Håkon Follestad	M	Autonomous Path-Planning and -Following for a Marine Surface Robot
2018	Name	Sex M/F	Topic
	Ingrid Mehn-Andersen	F	Time-domain Roll Motion Analysis of a Barge for Transportation of an Offshore Jacket Structure
	Anders Juul Weiby	M	Frequency-domain Roll Motion Analysis of a Transportation Barge Using Stochastic Linearization of Viscous Roll amping
	Jorge Luis Rangel Valdes	M	Dynamic Response Analysis of a Catamaran Wind Turbine Installation Vessel with focus on the Transportation Stage
	Guodong Liang	M	Frequency-domain Method for Global Dynamic Response Analysis of a Semi-submersible Floating Wind Turbine
	Tesse Marianne Balkema	F	Hydrodynamic Loads on an Inclined Monopile in the Splash Zone
	Brandon Thomas Pereyra	M	Design of a Counter Weight Suspension System for the TetraSpar Floating Offshore Wind Turbine
	Prateek Gupta	M	Subsea Installation, splash zone hydrodynamics
	Frid Grøtterud Birkeland	F	Accidental drop of pipes
	Helene Salte Håland	F	Accidental drop of pipes
	Amund Helvik	M	Radical installation methods
	Sebastian Eriksson	M	Large moonpools with recesses
	Morten Ravnås	M	Unstable two phase flow in long vertical pipes
	André Humlestøl Rongsøy	M	Development and verification of CFD methods for simulation of forces on ventilated structures
	Xiaoxuan Wan	F	Numerical time domain simulation of fully submerged object in subsea lifting
	Qian Yu	F	Estimate Dynamic Factors for Subsea Lifting operation by Using Experimental Method - Rapid Prototyping
	Odne Øyen Hovde	M	Comparing the vessel response by measuring the operability for fishing trawlers

Appendix 2 – List of Post-docs, Candidates for PhD and MSc degrees during the full period of the centre

2019	Name	Sex M/F	Topic
	Ramees Kalathingal Thody	M	Dynamic Response Analysis of Catmaran Installation Vessel During the Mating Process of a Wind Turbine onto a Floating Spar Buoy
	Hans Marius Remmen	M	Dynamic Response Analyses of a Semi-Sub Installation Vessel During the Installation of a Wind Turbine onto a Floating Spar Buoy
	Martin Håbet Tangen	M	Rapid Prototyping for Estimating Hydrodynamic Coefficients of Scaled Experiments on Subsea Structures during Lifting Operations
	Sondre Haug	M	Robust hybrid heading control of autonomous ships
	Håvard Løvås	M	DP autotuning by use of derivative-free optimization
	Merethe Tørresen	F	Multivariate Analysis of Ocean Currents in the Barents Sea
	Brynjar Abrahamsen	M	Fault Tolerant Dynamic Positioning for the Autonomous Test Platform ReVolt
	Karoline Vottestad	F	Experimental study on wave loads on porous plates in the splash zone
	Marius Robsahm	M	Experimental study on slamming loads on subsea modules in the splash zone
	Jon Kristian Voster	M	Experimental and theoretical study on porous plates in irregular waves
	Jonas Ravndal Kildal	M	Experimental, numerical and theoretical study on moonpool-vessel interaction in operational conditions
	Sunghun Hong	M	The effect of damping on the dynamic responses of a floating bridge in wind and waves
	Mela Schabrich	F	Coupled dynamic analysis of a floating dock system for installation of a spar wind turbine
	Johannes Bekker	M	Radial piston pumps: Performance and efficiency
	Huhnt Malte	M	Concept design of a floating support structure for hydrophilic crop
2020	Name	Sex M/F	Topic
	Jens Nikolai Alfsen	M	Dynamic optimal path-planning for autonomous harbor maneuvering
	Caroline Sophie Røhm Fleischer	F	Optimal path-planning on a bio-inspired neural network landscape model for autonomous surface vessels
	Hongyu Zhou	M	Autonomous guidance, stepwise path planning, and path-following control with anti-collision for autonomous marine robots
	Elias Gauslaa	M	Navigation, guidance, and control for autonomous autodocking of ships
	Jakob Stensvik Jensen	M	Dynamic optimal path-planning for autonomous harbor maneuvering
	Andrea Therese Rognstad	F	Numerical Study for Single Blade Installation of an Offshore Wind Turbine – Comparing a Jack-up and a Semi-submersible Crane Vessel in Intermediate Water Depths
	Ingeranne Strøm Nakstad	F	Numerical Study for Single Blade Installation of an Offshore Wind Turbine – Comparing a Jack-up and a Semi-submersible Crane Vessel in Intermediate Water Depths
	Thijs van Essen	M	Motion-Compensated Gripper Frame on a DP Vessel
	Piet H Bastiaanssen	M	Modelling the Dynamic Behaviour of a Rotor Nacelle Assembly during the Installation using a Floating Vessel
	Karoline Vottestad	F	Hydrodynamic Loads on Subsea Protection Structures
	Marius Robsahm	M	Experimental Study of Splash Zone Wave Loads on a Combined Configuration of a Porous Plate and a Circular Cylinder
	Jon Kristian Voster	M	Experimental and Numerical Investigations of Hydrodynamic Loads on Perforated Plates Subjected to Irregular Forced Oscillations

Appendix 2 – List of Post-docs, Candidates for PhD and MSc degrees during the full period of the centre

2021	Name	Sex M/F	Topic
	Øyvind Tro	M	Situational awareness in RLWI operations
	Sindre Sagsveen Slåtsum	M	Data-driven sea state estimation for a DP vessel based on distributed inertial measurement units
	Bjørn Wilhelm Jæger	M	Numerical Study on Offshore Wind Turbine Blade Installation by Utilizing a Floating Vessel
	Laura Slootweg	F	Single blade installation with a floating monohull crane vessel – Environmental limits and Tagline control
	Shuzhou Jiang	M	(Joint thesis) Installation of an offshore wind turbine blade using a jack-up installation vessel in water depth of 60 m
	Taewoo Kim	M	(Joint thesis) Installation of an offshore wind turbine blade using a jack-up installation vessel in water depth of 60 m
2022	Name	Sex M/F	Topic
	Saravanan Bhaskaran	M	Operational Limit Assessment of Offshore Wind Turbine Blade Root Mating Process Using Response-based Criteria
	Siren Huse	F	Forankring av flytende vindmøller
	Maiten Kase Corona	M	Tensegrity-Based Semi-Submersible Support Structure for a Floating Offshore Wind Turbine
	Servaas Sanders	M	Feasibility assessment of novel on-site installation methods for offshore Ultra Large Wind Turbines
	Lucas Lillie	M	Offshore hydrogen production - Analysis of different methods for hydrogen production using offshore wind
	Vignesh Balasubramanian	M	Load transfer from coupled analysis to structure design of FWTs
	Yu Ma	M	Novel modeling and fatigue analysis for early-phase design of a 15MW FOWT
	Fredrik Håland	M	Combining fully coupled analysis and linear potential theory time domain analysis to obtain cross sectional loads in the substructure of a floating offshore wind turbine
	Elias Strømmen Ravnstad	M	Time-domain wave estimation and prediction using wave radar on R/V Gunnerus
	Bjørn Theodor Torp Brørby	M	Wave load compensation in DP control systems
2023	Name	Sex M/F	Topic
	Daan Koetzier	M	Onsite blade exchange on a tension-leg platform floating wind turbine using a self-climbing crane
	Celine Wolfs	F	An analysis of the impact forces on a jack-up leg during installation on stiff seabed conditions
	Jadyr M. A. Peres	M	Offshore wind turbine blade installation – Development of a motion-compensated Stewart platform for blade installation with a floating vessel
	Florian Dach	M	Integration methods for floating offshore wind farms
	Marie Schrader Bordal	F	Design of Floating Offshore Wind Turbine Tower Structures
	Hanna Flem Bjørshol	F	Design of Floating Offshore Wind Turbine Tower Structures
	Sanne Lin Sætre	F	Deep Reinforcement Learning Based Parameter Optimisation for Installation Analysis of Marine Cables
	Håkon Mørkeseth	M	Time Domain Vortex-Induced Motion Prediction of Spar-Type Floating Wind Turbine
	Håkon Fallmyr	M	Numerical modelling and dynamic analysis of wind turbine rotor blade lifting operation from feeder barge using a jack-up vessel
	Adil Latif	M	Heavy maintenance of floating offshore wind turbines
	Luis Fernando Martin Sanchez	M	Online Digital Twin and a Decision Support for Safe Maneuvering of R/V Gunnerus
	Harald Mo	M	Real-time compensation of residual loads in dynamic positioning control systems
	Marie Fejerskov	F	Real-time compensation of residual loads in dynamic positioning control systems
	Jan-Erik Hygen	M	Deterministic Response Prediction of Wave-induced Vessel Motions

Publications 2015–2023

- 2015**
Pan, Yushan; Finken, Sisse; Komandur, Sashidharan.
 Are Current Usability Methods Viable for Maritime Operation Systems?. I: ACHI 2015, The Eighth International Conference on Advances in Computer-Human Interactions. 2015 ISBN 978-1-61208-382-7. s.161-167 NTNU UiO
- Longva, Vegard; Sævik, Svein.**
 A Lagrangian–Eulerian formulation for reeling analysis of history-dependent multilayered beams. Computers & structures 2015 ;Volum 146. s.44-58 NTNU
- Pan, Yushan.**
 A ten-minute talk - fieldwork stories. Høgskolen i Ålesund 2015 25 s. NTNU UiO
- Pan, Yushan.**
 Communications, Professionals, and Stressful Offshore Work – Organising, Managing and Improving Communication Channels. Dilemmas for Human Services 2015; 2015-09-09 - 2015-09-11 NTNU UiO
- Pan, Yushan.**
 Evaluating the Interactive Relations of Complex Systems: Offshore Operations as Research Resources - Doctoral Consortium. Dilemmas for Human Services 2015; 2015-09-09 - 2015-09-11 NTNU UiO
- Pan, Yushan.**
 Evaluating the Interactive Relations of Complex Systems: Offshore Operations as Research Resources - Poster. PhD day 2015; 2015-06-05 -2015-06-05 NTNU UiO
- Pan, Yushan; Komandur, Sashidharan; Finken, Sisse.**
 Complex Systems, Cooperative Work, and Usability. Journal of Usability Studies 2015 ;Volum 10.(3) s.100-112 NTNU UiO
- Ren, Zhengru; Skjetne, Roger; Hassani, Vahid.**
 Supervisory Control of Line Breakage for Thruster-Assisted Position Mooring System. 10th IFAC Conf. Manoeuvring and Control of Marine Craft; 2015-08-24 - 2015-08-26 NTNU
- Ren, Zhengru; Skjetne, Roger; Hassani, Vahid.**
 Supervisory Control of Line Breakage for Thruster-Assisted Position Mooring System. I: 10th IFAC Conference on Manoeuvring and Control of Marine Craft (MCMC 2015). Elsevier 2015 ISBN 978-3-902823-60-1. s.235-240 OCEAN NTNU
- Ren, Zhengru.**
 Fault Tolerant Control of Thruster-Assisted Position Mooring System. Norges teknisk-naturvitenskapelige universitet 2015 252 s. NTNU
- Ren, Zhengru; Skjetne, Roger; Kjerstad, Øivind Kåre.**
 A Tension-based Position Estimation Approach for Moored Marine Vessels. 10th IFAC Conf. Manoeuvring and Control of Marine Craft; 2015-08-24 - 2015-08-26 NTNU
- Ren, Zhengru; Skjetne, Roger; Kjerstad, Øivind Kåre.**
 A Tension-based Position Estimation Approach for Moored Marine Vessels. I: 10th IFAC Conference on Manoeuvring and Control of Marine Craft (MCMC 2015). Elsevier 2015 ISBN 978-3-902823-60-1. s.248-253 NTNU
- Skjetne, Roger.**
 Determining ice loads for OSVs. 6th Annual seminar on Design and Operation of OSVs for Ice and Cold Climates; 2015-11-30 - 2015-12-01 NTNU
- Thorsen, Mats Jørgen; Sævik, Svein; Larsen, Carl Martin.**
 Fatigue damage from time domain simulation of combined in-line and cross-flow vortex-induced vibrations. Marine Structures 2015 ;Volum 41. s.200-222 NTNU
- Thorsen, Mats Jørgen; Sævik, Svein; Larsen, Carl Martin.**
 Time Domain Simulation of Vortex-Induced Vibrations Based on Phase-Coupled Oscillator Synchronization. I: ASME 2015 34th International Conference on Ocean, Offshore and Arctic Engineering Volume 2: CFD and VIV. ASME Press 2015 ISBN 978-0-7918-5648-2. NTNU
- Yang, Xu; Sævik, Svein; Sun, Liping.**
 Numerical analysis of buckling failure in flexible pipe armor wires. Ocean Engineering 2015 ;Volum 108. s.594-605 NTNU
- Zhou, Chongyao; Sævik, Svein; Ye, Naiquan; Ji, Guomin.**
 Effect of lay angle of anti-buckling tape on lateral buckling behavior of tensile armors. I: Proceedings ASME 2015 34th International Conference on Ocean, Offshore and Arctic Engineering Volume 5A: Pipeline and Riser Technology. ASME Press 2015 ISBN 978-0-7918-5651-2. OCEAN NTNU
- 2016**
Sandvik, Peter Christian; Solaas, Frøydis; Firoozkoobi, Reza.
 Hydrodynamic forces on complex subsea structures. Marine Operations Specialty Symposium (MOSS 2016); 2016-09-20 OCEAN
- Agusta, Arifian; Ji, Guomin; Sævik, Svein.**
 Non-Linear Clay Soil Model for Lateral Pipe-Soil Interaction. I: ASME 2016 35th International Conference on Ocean, Offshore and Arctic Engineering - Volume 5: Pipelines, Risers, and Subsea Systems. ASME Press 2016 ISBN 978-0-7918-4996-5. OCEAN NTNU
- Chu, Yingguang; Pedersen, Birger Skogeng; Zhang, Houxiang.**
 Parameterization and Visualization of Marine Crane Concept Design. I: ASME 2016 35th International Conference on Ocean, Offshore and Arctic Engineering - Volume 7: Ocean Engineering. ASME Press 2016 ISBN 978-0-7918-4998-9. s.V007T06A095 NTNU
- Gao, Zhen; Moan, Torgeir; Wan, Ling; Michailidis, Konstantinos.**
 Comparative Numerical and Experimental Study of two Combined Wind and Wave Energy Concepts. Journal of Ocean Engineering and Science 2016 ;Volum 1.(1) s.36-51 NTNU
- Guachamin Acero, Wilson Ivan; Gao, Zhen; Moan, Torgeir.**
 Assessment of the Dynamic Responses and Allowable Sea States for a Novel Offshore Wind Turbine Tower and Rotor Nacelle Assembly Installation Concept Based on the Inverted Pendulum Principle. Energy Procedia 2016 ;Volum 94. s.61-71 NTNU

Guachamin Acero, Wilson Ivan; Li, Lin; Gao, Zhen; Moan, Torgeir.

Methodology for assessment of the operational limits and operability of marine operations. Ocean Engineering 2016 ;Volum 125. s.308-327
NTNU

Gutsch, Martin; Sprenger, Florian; Steen, Sverre.

Influence of Design Parameters on Operability of Offshore Construction Vessels. 111. Hauptversammlung der Schiffbautechnischen Gesellschaft e.V.; 2016-11-16 - 2016-11-18
OCEAN NTNU

Jin, Jingzhe; Solaas, Frøydis.

Comparison of direct and stationary approach in prediction of lift wire tension in splash zone crossing operation. Marine Operations Specialty Symposium (MOSS 2016); 2016-09-20 - 2016-09-21
OCEAN

Knudsen, Tor Huse; Sævik, Svein; Thorsen, Mats Jørgen.

Numerical Analysis of Combined VIV and Slug Flow in Time Domain. OMAE 2016; 2016-06-19 - 2016-06-24
NTNU

Kyllingstad, Lars Tandle.

Simulation technology and virtual prototyping as a common approach from design to operation. MOVE Autumn Conference 2016; 2016-10-18 - 2016-10-19
OCEAN

Kyllingstad, Lars Tandle.

Simulering av maritime systemer. Maritim innovasjonsdialog: Utvikling av numerisk modelltank inkludert valg av maskineriløsninger; 2 016-11-21 - 2016-11-21
OCEAN

Li, Guoyuan; Pedersen, Birger Skogeng; Deng, Yuxiang; Hatledal, Lars Ivar; Zhang, Houxiang.

Towards A Virtual Prototyping Framework for Ship Maneuvering in Offshore Operations. I: OCEANS 2016 Shanghai - MTS/IEEE. IEEE conference proceedings 2016 ISBN 978-1-4673-9723-0.
NTNU

Li, Guoyuan; Zhang, Houxiang; Kawan, Bikram; Wang, Hao; Osen, Ottar; Styve, Arne.

Analysis and Modeling of Sensor Data for Ship Motion Prediction. I: OCEANS 2016 Shanghai - MTS/IEEE. IEEE conference proceedings 2016 ISBN 978-1-4673-9723-0.
NTNU

Li, Lin; Gao, Zhen; Moan, Torgeir.

Operability Analysis of Monopile Lowering Operation Using Different Numerical Approaches. International Journal of Offshore and Polar Engineering 2016 ;Volum 26.(2) s.88-99
NTNU

Li, Lin; Guachamin Acero, Wilson Ivan; Gao, Zhen; Moan, Torgeir.

Assessment of Allowable Sea States During Installation of OWT Monopiles with Shallow Penetration in the Seabed. Journal of Offshore Mechanics and Arctic Engineering 2016 ;Volum 138.(4) Suppl. 041902.
NTNU

Li, Yue; Halse, Karl Henning; Xu, Jiafeng.

Sloshing flows in a free surface anti roll tank - Numerical simulations and experimental validation. I: Proceedings of the 13th International Symposium on PRACTical Design of Ships and Other Floating Structures (PRADS' 2016). Danmarks Tekniske Universitet, DTU 2016 ISBN 978-87-7475-473-2. s.313-320
NTNU

Longva, Vegard; Sævik, Svein.

On prediction of torque in flexible pipe reeling operations using a Lagrangian-Eulerian FE framework. Marine Structures 2016 ;Volum 46. s.229-254
NTNU

Ommani, Babak; Kristiansen, Trygve; Berget, Kjetil; Sandvik, Peter Christian; Faltinsen, Odd Magnus.

Investigation on Moonpool Blockage by Box Shaped Object Close to Free Surface. 3rd International Conference on Violent Flows (VF-2016); 2016-03-09 - 2016-03-11
OCEAN NTNU

Pan, Yushan.

Cooperative Systems for Marine Operations Using Actor-Network Design: A Discussion. I: Proceedings of the 2016 IEEE 20th International Conference on Computer Supported Cooperative Work in Design(CSCWD). IEEE conference proceedings 2016 ISBN 978-1-5090-1914-4. s.607-612
NTNU

Pan, Yushan.

Design of Digital Environments for Operations on Vessels. I: COOP 2016: Proceedings of the 12th International Conference on the Design of Cooperative Systems, 23-27 May 2016, Trento, Italy. Springer Publishing Company 2016 ISBN 978-3-319-33463-9. s.123-138
NTNU

Pan, Yushan.

Improving maritime technology: A cooperation technology perspective on cooperative artifacts. I: OCEANS 2016 Shanghai - MTS/IEEE. IEEE conference proceedings 2016 ISBN 978-1-4673-9723-0.
NTNU UiO

Pan, Yushan; Finken, Sisse.

Visualising Actor Network for Cooperative Systems in Marine Technology. HCC12 2016, IFIP AICT 474; 2016-09-07 - 2016-09-09
NTNU UiO

Pan, Yushan; Finken, Sisse.

Visualising actor network for cooperative systems in marine technology. I: Technology and Intimacy: Choice or Coercion. Springer Publishing Company 2016 ISBN 978-3-319-44804-6. s.178-190
NTNU UiO

Pan, Yushan; Hildre, Hans-Petter.

Using Actor Network to Enhance Maritime System Design. Learning and Collaboration Technologies, LTC 2016, Held as Part of HCI International 2016; 2016-07-17 - 2016-07-22
NTNU UiO

Pan, Yushan; Hildre, Hans-Petter.

Using Actor Network to Enhance Maritime System Design. I: Learning and Collaboration Technologies. Springer Publishing Company 2016 s.616-627
NTNU UiO

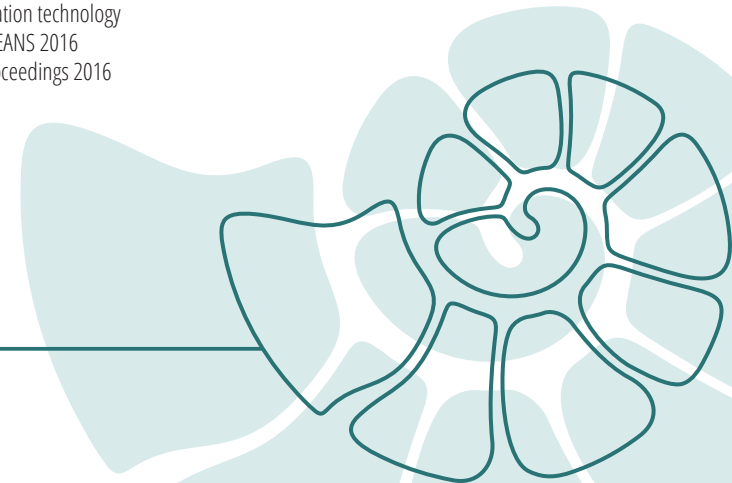

Appendix 3 – List of Publications

Ren, Zhengru; Skjetne, Roger.

A Tension-based Position Estimation Solution of a Moored Structure and its Uncertain Anchor Positions. The 10th IFAC Conference on Control Applications in Marine Systems (CAMS 2016); 2016-09-13 - 2016-09-16 NTNU

Ren, Zhengru; Skjetne, Roger.

A Tension-based Position Estimation Solution of a Moored Structure and its Uncertain Anchor Positions. IFAC-PapersOnLine 2016 ;Volum 49.(23) s.251-257 NTNU

Ren, Zhengru; Skjetne, Roger.

An On-site Current Profile Estimation Algorithm for a Moored Floating Structure. IFAC-PapersOnLine 2016 ;Volum 49.(23) s.153-158 NTNU

Ren, Zhengru; Skjetne, Roger.

An On-site Current Profile Estimation Algorithm for a Moored Floating Structure. The 10th IFAC Conference on Control Applications in Marine Systems (CAMS 2016); 2016-09-13 - 2016-09-16 NTNU

Sandvik, Peter Christian; Solaas, Frøydis; Firoozkoobi, Reza.

Hydrodynamic forces on complex subsea structures. Some results from a Norwegian research based innovation program.. Marine Operations Specialty Symposium (MOSS 2016); 2016-09-20 OCEAN

Tang, Meng.

The Architecture of deep Sea Mining Lift System. Workshop on Ocean Mining 11th May 2016; 2016-05-11 - 2016-05-11

Thorsen, Mats Jørgen; Sævik, Svein; Larsen, Carl Martin.

Time domain simulation of vortex-induced vibrations in stationary and oscillating flows. Journal of Fluids and Structures 2016 ;Volum 61. s.1-19 NTNU

Værnø, Svern Are Tutturen; Brodtkorb, Astrid H.; Skjetne, Roger; Sørensen, Asgeir Johan.

An Output Feedback Controller with Improved Transient Response of Marine Vessels in Dynamic Positioning. IFAC-PapersOnLine 2016 ;Volum 49.(23) s.133-138 NTNU

Wang, Hao; Fossen, Sindre; Han, Fang; Hameed, Ibrahim A.; Li, Guoyuan.

Towards data-driven identification and analysis of propeller ventilation. I: OCEANS 2016 Shanghai - MTS/IEEE. IEEE conference proceedings 2016 ISBN 978-1-4673-9723-0. NTNU

Wang, Hao; Zhuge, Xu; Strazdins, Girts; Wei, Zheng; Li, Guoyuan; Zhang, Houxiang.

Data integration and visualisation for demanding marine operations. I: OCEANS 2016 Shanghai - MTS/IEEE. IEEE conference proceedings 2016 ISBN 978-1-4673-9723-0. NTNU

Xu, Jiafeng.

A Marine Simulation Framework and A Dual Quaternion Variational Integrator. MOVE Autumn Conference 2016; 2016-10-18 - 2016-10-19 NTNU

Xu, Jiafeng; Halse, Karl Henning.

Dual Quaternion Variational Integrator for Rigid Body Dynamic Simulation. arxiv.org 2016 27 s. NTNU

2017

Challabotla, Niranjan Reddy.

Model development for ocean mining lift system. OCEAN WEEK 2017; 2017-05-03 - 2017-05-05 NTNU

Dai, Tianjiao; Sævik, Svein; Ye, Naiquan.

Friction models for evaluating dynamic stresses in non-bonded flexible risers. Marine Structures 2017 ;Volum 55. s.137-161 NTNU OCEAN

Dai, Tianjiao; Ye, Naiquan; Sævik, Svein.

OMAE2017-62644 The Effect of Stick Stiffness of Friction Models on the Bending Behavior in Non-Bonded Flexible Risers. I: ASME 2017 36th International Conference on Ocean, Offshore and Arctic Engineering - Volume 5A: Pipelines, Risers, and Subsea Systems. ASME Press 2017 ISBN 978-0-7918-5769-4. OCEAN NTNU

Guachamin Acero, Wilson Ivan; Gao, Zhen; Moan, Torgeir.

Methodology for assessment of the allowable sea states during installation of an offshore Wind turbine transition piece structure onto a monopile foundation. Journal of Offshore Mechanics and Arctic Engineering 2017 ;Volum 139.(6) NTNU

Guachamin Acero, Wilson Ivan; Gao, Zhen; Moan, Torgeir.

Numerical study of a novel procedure for installing the tower and Rotor Nacelle Assembly of offshore wind turbines based on the inverted pendulum principle. Journal of Marine Science and Application 2017 ;Volum 16.(3) s.243-260 NTNU

Gutsch, Martin; Sprenger, Florian.

VESSEL PERFORMANCE - Progress Update on Work in RA1. MOVE Spring Conference 2017; 2017-04-05 - 2017-04-05 OCEAN NTNU

Gutsch, Martin; Sprenger, Florian; Steen, Sverre.

OMAE2017-62307 - Design Parameters for Increased Operability of Offshore Crane Vessels. OMAE 2017; 2017-06-25 - 2017-06-30 OCEAN NTNU

Gutsch, Martin; Sprenger, Florian; Steen, Sverre.

Design parameters for increased operability of offshore crane vessels. I: ASME 2017 36th International Conference on Ocean, Offshore and Arctic Engineering - Volume 9: Offshore Geotechnics; Torgeir Moan Honoring Symposium. The American Society of Mechanical Engineers (ASME) 2017 ISBN 978-0-7918-5777-9. OCEAN NTNU

Gutsch, Martin; Sprenger, Florian; Steinebach, Christian.

Performance Indicators for Subsea Lifting Operations - Report of 1st Marine Operations Forum. Ålesund: SFI Move 2017 17 s. OCEAN NTNU

Halse, Karl Henning.

Offshore Wind Project 2017 - Innovative Installation of Floating Wind Power Systems. MOVE autumn conference 2017; 2017-11-22 NTNU

Halse, Karl Henning.

Project 5 - Offshore Wind. MOVE Spring Conference 2017; 2017-04-05 - 2017-04-05 NTNU

Hatledal, Lars Ivar; Zhang, Houxiang; Halse, Karl Henning; Hildre, Hans Petter.

Numerical Study for a Catamaran Gripper-Monopile Mechanism of a Novel Offshore Wind Turbine Assembly Installation Procedure. I: ASME 2017 36th International Conference on Ocean, Offshore and Arctic Engineering - Volume 9: Offshore Geotechnics; Torgeir Moan Honoring Symposium. ASME Press 2017 ISBN 978-0-7918-5777-9. NTNU

Hildre, Hans Petter.

Summary SFI-MOVE Conference, November 2017. SFI Conference Autumn 2017; 2017-11-22 - 2017-11-22
NTNU

Jiang, Zhiyu.

Recent progress on numerical simulations of the catamaran installation vessel concept. MOVE autumn conference 2017; 2017-11-21 - 2017-11-22
NTNU

Jiang, Zhiyu; Guachamin Acero, Wilson Ivan; Gao, Zhen; Li, Lin.

A Numerical Study on a Flopper Stopper for Leg Positioning of a Jack-Up Barge. I: ASME 2017 36th International Conference on Ocean, Offshore and Arctic Engineering - Volume 9: Offshore Geotechnics; Torgeir Moan Honoring Symposium. The American Society of Mechanical Engineers (ASME) 2017 ISBN 978-0-7918-5777-9. s.1-13
UIS NTNU

Jiang, Zhiyu; Hu, Weifei; Dong, Wenbin; Gao, Zhen; Ren, Zhengru.

Structural reliability analysis of wind turbines: A review. Energies 2017 ;Volum 10.(12)
NTNU

Johannessen, Silje Aarvik.

Autonomous heading control in position mooring with thruster assist. Norges teknisk-naturvitenskapelige universitet 2017 127 s.
NTNU

Kyllingstad, Lars Tandle; Skulstad, Robert.

MOVE project 3: Simulation technology and virtual prototyping as a common approach from design to operation. MOVE spring conference 2017; 2017-04-05
OCEAN NTNU

Mentzoni, Fredrik.

All year subsea - hydrodynamics of complex structures. MOVE autumn conference 2017; 2017-11-22
NTNU

Nematbakhsh, Ali; Gao, Zhen; Moan, Torgeir.

Benchmarking of a computational fluid dynamics- based numerical wave tank for studying wave load effects on fixed and floating offshore structures. Journal of Offshore Mechanics and Arctic Engineering 2017 ;Volum 139.(3)
NTNU

Pan, Yushan; Hildre, Hans Petter.

Holistic human safety in the design of marine operations safety. Ocean Engineering 2017 ;Volum 151. s.378-389
NTNU

Ren, Zhengru; Skjetne, Roger; Gao, Zhen.

Modeling and control of crane overload protection during marine lifting operation based on model predictive control. I: ASME 2017 36th International Conference on Ocean, Offshore and Arctic Engineering - Volume 9: Offshore Geotechnics; Torgeir Moan Honoring Symposium. The American Society of Mechanical Engineers (ASME) 2017 ISBN 978-0-7918-5777-9.
NTNU

Ren, Zhengru; Skjetne, Roger; Gao, Zhen.

Problem Formulation: Control Questions in Wind Turbine Installation. SFI MOVE conference; 2017-04-04 - 2017-04-05
NTNU

Skulstad, Robert.

Ship motion prediction using neural networks. Move autumn conference 2017; 2017-11-22 - 2017-11-22
NTNU

Solaas, Frøydis.

Hydrodynamic coefficients and their use in numerical simulations of lifting operations. MOVE spring conference 2017; 2017-04-05 - 2017-04-05
OCEAN

Solaas, Frøydis.

SFI-MOVE Case study: Numerical Simulations of Johan Sverdrup ITS Installation. SFI MOVE-conference; 2017-11-22 - 2017-11-22
OCEAN

Solaas, Frøydis; Sandvik, Peter Christian.

OMAE2017-62447 Hydrodynamic Coefficients for Suction Anchors during Installation Operations. OMAE 2017; 2017-06-25 - 2017-06-30
OCEAN

Solaas, Frøydis; Sandvik, Peter Christian; Pakozdi, Csaba; Kendon, Timothy Edward; Larsen, Kjell; Myhre, Erling.

OMAE2017-62499 Dynamic Forces and Limiting Sea States for Installation of GRP Protection Covers. OMAE 2017; 2017-06-25 - 2017-06-30
OCEAN

Solaas, Frøydis; Sandvik, Peter Christian; Pakozdi, Csaba; Kendon, Timothy Edward; Larsen, Kjell; Myhre, Erling.

OMAE2017-62499 Dynamic Forces and Limiting Sea States for Installation of GRP Protection Covers. I: ASME 2017 36th International Conference on Ocean, Offshore and Arctic Engineering - Volume 9: Offshore Geotechnics; Torgeir Moan Honoring Symposium. ASME Press 2017 ISBN 978-0-7918-5777-9.
OCEAN

Solaas, Frøydis; Sandvik, Peter Christian.

OMAE2017-62447 Hydrodynamic Coefficients for Suction Anchors during Installation Operations. I: ASME 2017 36th International Conference on Ocean, Offshore and Arctic Engineering - Volume 9: Offshore Geotechnics; Torgeir Moan Honoring Symposium. ASME Press 2017 ISBN 978-0-7918-5777-9.
OCEAN

Sprenger, Florian; Gutsch, Martin; Sandvik, Peter Christian; Steinebach, Christian.

1st Marine Operations Forum - Performance Indicators for Subsea Lifting Operations. Marine Operations Forum; 2017-02-07 - 2017-02-07
OCEAN NTNU

Sævik, Svein.

Exploration of Technologies to Develop Ocean Mining as a new Business Area. MOVE spring conference 2017; 2017-04-05 - 2017-04-05
NTNU

Sævik, Svein; Thorsen, Mats Jørgen.

An Analytical Treatment of Buckling and Instability of Tensile Armors in Flexible Pipes. Journal of Offshore Mechanics and Arctic Engineering 2017 ;Volum 139.(4) s.041701-1-041701-6
NTNU

Thorsen, Mats Jørgen.

Coupled dynamic analysis of pipes subjected to VIV and internal two-phase flow. SFI MOVE konferanse; 2017-11-22 - 2017-11-22
NTNU

Thorsen, Mats Jørgen.

Riser Dynamics in Deep Sea Mining. Ocean Week 2017; 2017-05-03
NTNU

Appendix 3 – List of Publications

Thorsen, Mats Jørgen; Sævik, Svein.

Simulating Riser VIV in Current and Waves Using an Empirical Time Domain Model. I: ASME 2017 36th International Conference on Ocean, Offshore and Arctic Engineering - Volume 2: Prof. Carl Martin Larsen and Dr. Owen Oakley Honoring Symposia on CFD and VIV. The American Society of Mechanical Engineers (ASME) 2017 ISBN 978-0-7918-5764-9.
NTNU

Thorsen, Mats Jørgen; Sævik, Svein.

Vortex-induced vibrations of a vertical riser with time-varying tension. Procedia Engineering 2017 ;Volum 199. s.1326-1331
NTNU

Thorsen, Mats Jørgen; Sævik, Svein; Larsen, Carl Martin.

Non-linear time domain analysis of cross-flow vortex-induced vibrations. Marine Structures 2017 ;Volum 51. s.134-151
NTNU

Ulveseter, Jan Vidar; Sævik, Svein.

In-Line Vibrations of Flexible Pipes. I: ASME 2017 36th International Conference on Ocean, Offshore and Arctic Engineering - Volume 2: Prof. Carl Martin Larsen and Dr. Owen Oakley Honoring Symposia on CFD and VIV. ASME Press 2017 ISBN 978-0-7918-5764-9.
NTNU

Ulveseter, Jan Vidar; Sævik, Svein; Larsen, Carl Martin.

Time domain model for calculation of pure in-line vortex-induced vibrations. Journal of Fluids and Structures 2017; Volum 68. s.158-173
NTNU

Ulveseter, Jan Vidar; Thorsen, Mats Jørgen; Sævik, Svein; Larsen, Carl Martin.

Stochastic modelling of cross-flow vortex-induced vibrations. Marine Structures 2017 ;Volum 56. s.260-280
NTNU

Verma, Amrit Shankar.

Response-based criteria for blade damage during installation. SFI MOVE autumn conference, Ålesund, 22 November, 2017; 2017-11-22 - 2017-11-22
NTNU

Verma, Amrit Shankar; Vedvik, Nils Petter; Gao, Zhen.

Numerical assessment of wind turbine blade damage due to contact/impact with tower during installation. IOP Conference Series: Materials Science and Engineering 2017 ;Volum 276.
NTNU

Værnø, Sverre Are Tutturen; Brodtkorb, Astrid H.; Skjetne, Roger; Vincenzo, Calabro.

Time-Varying Model-Based Observer for Marine Surface Vessels in Dynamic Positioning. IEEE Access 2017 ; Volum 5. s.14787-14796
NTNU

Xu, Jiafeng; Ren, Zhengru; Li, Yue; Skjetne, Roger; Halse, Karl Henning.

Dynamic Simulation and Control of an Active Roll Reduction System Using Free-Flooding Tanks With Vacuum Pumps. I: ASME 2017 36th International Conference on Ocean, Offshore and Arctic Engineering - Volume 1: Offshore Technology. The American Society of Mechanical Engineers (ASME) 2017 ISBN 978-0-7918-5763-2.
NTNU

YU, Feilong; Chu, Yingguang; Zhang, Houxiang; Æsøy, Vilmar.

Parallel Force/Position Control of Motion Compensated Gangway in Offshore Operations. International Conference on Ships and Offshore Structures; 2017-09-11 - 2017-09-13
NTNU

2018

Challabotla, Niranjan Reddy; Smith, Ivar Eskerud; Nydal, Ole Jørgen; Sævik, Svein.

Simulation of two-phase flow in airlift pump using 1D two-fluid model. Underwater Mining Conference 2018; 2018-09-10 - 2018-09-14
NTNU SINTEF

Cheng, Xu; Skulstad, Robert; Li, Guoyuan; Chen, Shengyong; Hildre, Hans Petter; Zhang, Houxiang.

A data-driven sensitivity analysis approach for dynamically positioned vessels. I: Proceedings of The 59th Conference on Simulation and Modelling (SIMS 59). Linköping University Electronic Press 2018 ISBN 978-91-7685-494-5. s.156-161
NTNU

Chu, Yingguang; Hatledal, Lars Ivar; Zhang, Houxiang; Æsøy, Vilmar; Ehlers, Sören.

Virtual prototyping for maritime crane design and operations. Journal of Marine Science and Technology 2018 ;Volum 23.(4) s.754-766
NTNU

Chu, Yingguang; Hatledal, Lars Ivar; Æsøy, Vilmar; Ehlers, Sören; Zhang, Houxiang.

An Object-Oriented Modeling Approach to Virtual Prototyping of Marine Operation Systems Based on Functional Mock-Up Interface CoSimulation. Journal of Offshore Mechanics and Arctic Engineering 2018 ; Volum 140.(2) s.1-9
NTNU

Dai, Tianjiao; Sævik, Svein; Ye, Naiquan.

An anisotropic friction model in non-bonded flexible risers. Marine Structures 2018 ;Volum 59. s.423-443
OCEAN NTNU

Gao, Zhen; Verma, Amrit Shankar; Zhao, Yuna; Jiang, Zhiyu; Ren, Zhengru.

A Summary of the Recent Work at NTNU on Marine Operations Related to Installation of Offshore Wind Turbines. I: ASME 2018 37th International Conference on Ocean, Offshore and Arctic Engineering - Volume 11A: Honoring Symposium for Professor Carlos Guedes Soares on Marine Technology and Ocean Engineering. The American Society of Mechanical Engineers (ASME) 2018 ISBN 978-0-7918-5132-6.
NTNU

Gutsch, Martin.

Vessel Response Tool - Comparative evaluation of vessel motion behavior. SFI MOVE Autumn Conference 2018; 2018-11-27 - 2018-11-27
NTNU

Gutsch, Martin.

Weighting of Performance Indicators for Onshore Lifting Operations - 2nd Marine Operations Forum 2018. SINTEF Ocean AS 2018 25 s.
OCEAN NTNU

Gutsch, Martin.

2nd Marine Operations Forum - Review and Weighting of Performance Indicators for Offshore Lifting Operations Over Vessel Side. Marine Operations Forum; 2018-04-20 - 2018-04-20
NTNU

Jiang, Zhiyu; Ren, Zhengru; Gao, Zhen; Sandvik, Peter Christian; Halse, Karl Henning; Skjetne, Roger.

Mating Control of a Wind Turbine Tower-Nacelle-Rotor Assembly for a Catamaran Installation Vessel. Twenty-eighth (2018) International Ocean and Polar Engineering Conference; 2018-06-10 - 2018-06-15
OCEAN NTNU

Jiang, Zhiyu; Ren, Zhengru; Gao, Zhen; Sandvik, Peter Christian; Halse, Karl Henning; Skjetne, Roger.

Mating Control of a Wind Turbine Tower-Nacelle-Rotor Assembly for a Catamaran Installation Vessel. I: The Proceedings of The Twenty-eighth (2018) International OCEAN AND POLAR ENGINEERING CONFERENCE, ISOPE 2018. International Society of Offshore & Polar Engineers 2018 ISBN 978-1-880653-87-6. s.584-593
NTNU

Jin, Jingzhe; Jiang, Zhiyu; Vatne, Sigrid Ringdalen; Ren, Zhengru; Zhao, Yuna; Gao, Zhen.

Installation of Pre-assembled Offshore Wind Turbine Using a Catamaran Vessel and an Active Gripper Motion Control Method. International Conference and Exhibition on Grand Renewable Energy; 2018-06-17 - 2018-06-22
OCEAN NTNU

Mentzoni, Fredrik; Abrahamsen-Prsic, Mia; Kristiansen, Trygve.

Hydrodynamic Coefficients of Simplified Subsea Structures. I: ASME 2018 37th International Conference on Ocean, Offshore and Arctic Engineering - Volume 1: Offshore Technology -. The American Society of Mechanical Engineers (ASME) 2018 ISBN 978-0-7918-5120-3.
NTNU

Mentzoni, Fredrik; Solaas, Frøydis.

Hydrodynamic coefficients for subsea structures – What it's all about?. MOVE autumn conference 2018; 2018-11-27 - 2018-11-27
OCEAN NTNU

Pan, Yushan; Finken, Sisse.

From Offshore Operation to Onshore Simulator: Using Visualized Ethnographic Outcomes to Work with Systems Developers. Informatics 2018;Volum 5.(1)
NTNU UiO

Ren, Zhengru; Jiang, Zhiyu; Gao, Zhen; Skjetne, Roger.

Active tugger line force control for single blade installation. Wind Energy 2018 ;Volum 21.(12)
s.1344-1358
NTNU

Ren, Zhengru; Jiang, Zhiyu; Skjetne, Roger; Gao, Zhen.

Development and application of a simulator for offshore wind turbine blades installation. Ocean Engineering 2018 ;Volum 166. s.380-395
NTNU

Ren, Zhengru; Jiang, Zhiyu; Skjetne, Roger; Gao, Zhen.

Single blade installation using active control of three tugger lines. I: The Proceedings of The Twenty-eighth (2018) International OCEAN AND POLAR ENGINEERING CONFERENCE, ISOPE 2018. International Society of Offshore & Polar Engineers 2018
ISBN 978-1-880653-87-6. s.594-601
NTNU

Sandvik, Endre; Gutsch, Martin; Asbjørnslett, Bjørn Egil.

A simulation-based ship design methodology for evaluating susceptibility to weather-induced delays during marine operations. Ship Technology Research 2018 ;Volum 65.(3) s.137-152
NTNU

Skulstad, Robert; Li, Guoyuan; Zhang, Houxiang; Fossen, Thor I..

A Neural Network Approach to Control Allocation of Ships for Dynamic Positioning. IFAC-PapersOnLine 2018 ;Volum 51.(29) s.128-133
NTNU

Thorsen, Mats Jørgen; Sævik, Svein.

An Analytical Model of the Effect of Internal Density Waves in Risers Subjected to Vortex Shedding. I: The Proceedings of The Twenty-eighth (2018) International OCEAN AND POLAR ENGINEERING CONFERENCE, ISOPE 2018. International Society of Offshore & Polar Engineers 2018 ISBN 978-1-880653-87-6. s.168-175
NTNU

Ulveseter, Jan Vidar; Thorsen, Mats Jørgen; Sævik, Svein; Larsen, Carl Martin.

Time domain simulation of riser VIV in current and irregular waves. Marine Structures 2018 ;Volum 60. s.241-260
NTNU

Verma, Amrit Shankar; Haselbach, Philipp Ulrich; Vedvik, Nils Petter; Gao, Zhen.

A Global-local Damage Assessment Methodology for Impact Damage on Offshore Wind Turbine Blades during Lifting Operations. I: ASME 2018 37th International Conference on Ocean, Offshore and Arctic Engineering - Volume 10: Ocean Renewable Energy. ASME Press 2018
ISBN 978-0-7918-5131-9.
NTNU

Wang, Chunlin; Cheng, Xu; Chen, Shengyong; Li, Guoyuan; Zhang, Houxiang.

A SVM-based Sensitivity Analysis Approach for Data-Driven Modeling of Ship Motion. I: Proceedings of 2018 IEEE Int. Conf. on Mechatronics and Automation. IEEE conference proceedings 2018 ISBN 978-1-5386-6075-1. s.803-808
NTNU

Wu, Mengning; Stefanakos, Christos; Gao, Zhen.

Prediction of Short-term Wind and Wave Conditions Using Adaptive Network-based Fuzzy Inference System (ANFIS) for Marine Operations. I: Proceedings of the 3rd International Conference on Renewable Energies Offshore (RENEW) 2018. CRC Press 2018 ISBN 9781138585355. s.83-94
OCEAN NTNU

Xu, Jiafeng; Ren, Zhengru; Li, Yue; Skjetne, Roger; Halse, Karl Henning.

Dynamic Simulation and Control of an Active Roll Reduction System Using Free-Flooding Tanks With Vacuum Pumps [J]. Journal of Offshore Mechanics and Arctic Engineering 2018 ;Volum 140.(6)
NTNU

Zhao, Yuna; Cheng, Zhengshun; Sandvik, Peter Christian; Gao, Zhen; Moan, Torgeir.

An integrated dynamic analysis method for simulating installation of single blades for wind turbines. Ocean Engineering 2018 ;Volum 152. s.72-88
NTNU

Zhao, Yuna; Cheng, Zhengshun; Sandvik, Peter Christian; Gao, Zhen; Moan, Torgeir; van Buren, Eric.

Numerical Modelling and Analysis of the Dynamic Motion Response of an Offshore Wind Turbine Blade during Installation by a Jack-Up Crane Vessel. Ocean Engineering 2018 ;Volum 165. s.353-364
NTNU

Appendix 3 – List of Publications

- 2019**
Cai, Yueri; Bi, Shusheng; Li, Guoyuan; Hildre, Hans Petter; Zhang, Houxiang.
From Natural Complexity to Biomimetic Simplification: The Realization of Bionic Fish Inspired by the Cownose Ray. IEEE robotics & automation magazine 2019 ;Volum 26.(3) s.27-38
NTNU
- Cai, Yueri; Ren, Xingwei; Bi, Shusheng; Li, Guoyuan; Hildre, Hans Petter; Zhang, Houxiang.**
Hydrodynamic development of a bionic pectoral fin for undersea monitoring platform. Ships and Offshore Structures 2019 ;Volum 14. s.91-99
NTNU
- Cheng, Xu; Ellefsen, Andre; Li, Guoyuan; Holmeset, Finn Tore; Zhang, Houxiang; Chen, Shengyong.**
A Step-wise Feature Selection Scheme for a Prognostics and Health Management System in Autonomous Ferry Crossing Operation. I: Proceedings of 2019 IEEE International Conference on Mechatronics and Automation August 4 - 7, Tianjin, China. IEEE 2019 ISBN 978-1-7281-1699-0. s.1877-1882
NTNU
- Cheng, Xu; Li, Guoyuan; Skulstad, Robert; Chen, Shengyong; Hildre, Hans Petter; Zhang, Houxiang.**
Modeling and Analysis of Motion Data from Dynamically Positioned Vessels for Sea State Estimation. I: 2019 International Conference on Robotics and Automation (ICRA 2019). IEEE 2019 ISBN 978-1-5386-6027-0. s.6644-6650
NTNU
- Cheng, Xu; Li, Guoyuan; Skulstad, Robert; Major, Pierre Yann; Chen, Shengyong; Hildre, Hans Petter; Zhang, Houxiang.**
Data-driven uncertainty and sensitivity analysis for ship motion modeling in offshore operations. Ocean Engineering 2019 ;Volum 179. s.261-272
NTNU
- Gutsch, Martin.**
Next Generation Vessel Response Tool. SFI MOVE Autumn Conference; 2019-11-27 - 2019-11-28
NTNU OCEAN
- Gutsch, Martin.**
Review of requirements on ship design optimization tools. SFI-MOVE Spring Conference; 2019-05-10 - 2019-05-10
OCEAN NTNU
- Kari, Raheleh; Steinert, Martin; Gaspar, Henrique Murilo.**
EEG Application for Human-Centered Experiments in Remote Ship Operations. I: CENTRIC 2019, The Twelfth International Conference on Advances in Human oriented and Personalized Mechanisms, Technologies, and Services. International Academy, Research and Industry Association (IARIA) 2019 ISBN 978-1-61208-754-2. s.17-23
NTNU
- Li, Guoyuan; Hildre, Hans Petter; Zhang, Houxiang.**
Toward Time-Optimal Trajectory Planning for Autonomous Ship Maneuvering in Close-Range Encounters. IEEE Journal of Oceanic Engineering 2019
NTNU
- Mao, Runze; Li, Guoyuan; Hildre, Hans Petter; Zhang, Houxiang.**
Analysis and evaluation of eye behavior for marine operation training - A pilot study. Journal of Eye Movement Research 2019 ;Volum 12.(3)
NTNU
- Mentzoni, Fredrik; Kristiansen, Trygve.**
A Semi-Analytical Method for Calculating the Hydrodynamic Force on Perforated Plates in Oscillating Flow. I: ASME 2019 38th International Conference on Ocean, Offshore and Arctic Engineering. Volume 7A: Ocean Engineering. The American Society of Mechanical Engineers (ASME) 2019 ISBN 978-0-7918-5884-4.
NTNU
- Mentzoni, Fredrik; Kristiansen, Trygve.**
Numerical modeling of perforated plates in oscillating flow. Applied Ocean Research 2019 ;Volum 84. s.1-11
NTNU
- Monteiro, Thiago Gabriel; Skourup, Charlotte; Zhang, Houxiang.**
Using EEG for Mental Fatigue Assessment: A Comprehensive Look Into the Current State of the Art. IEEE Transactions on Human-Machine Systems 2019 ;Volum 49.(6) s.599-610
NTNU
- Monteiro, Thiago Gabriel; Zhang, Houxiang; Skourup, Charlotte; Aoun Tannuri, Eduardo.**
Detecting Mental Fatigue in Vessel Pilots Using Deep Learning and Physiological Sensors. I: Proceedings of the 15th IEEE International Conference on Control and Automation. IEEE conference proceedings 2019 ISBN 978-1-7281-1163-6. s.1511-1516
NTNU
- Ren, Zhengru.**
Advanced Control Algorithms to Support Automated Offshore Wind Turbine Installation. Norges teknisk-naturvitenskapelige universitet 2019 (ISBN 978-82-326-4058-4) 220 s.
NTNU
- Ren, Zhengru; Skjetne, Roger; Gao, Zhen.**
A Crane Overload Protection Controller for Blade Lifting Operation Based on Model Predictive Control. Energies 2019 ;Volum 12.(1) Suppl. 50.s.1-22
NTNU
- Ren, Zhengru; Skjetne, Roger; Jiang, Zhiyu; Gao, Zhen; Verma, Amrit Shankar.**
Integrated GNSS/IMU Hub Motion Estimator for Offshore Wind Turbine Blade Installation. Mechanical systems and signal processing 2019 ;Volum 123. s.222-243
UIA NTNU
- Sant'Ana, Mateus; Li, Guoyuan; Zhang, Houxiang.**
A decentralized sensor fusion approach to human fatigue monitoring in maritime operations. I: Proceedings of the 15th IEEE International Conference on Control and Automation. IEEE conference proceedings 2019 ISBN 978-1-7281-1163-6. s.1569-1574
NTNU
- Skjong, Stian; Kyllingstad, Lars Tandle; Reite, Karl Johan; Haugen, Joakim; Ladstein, Jarle; Aarsæther, Karl Gunnar.**
Generic on-board decision support system framework for marine operations. ASME 2019 38th International Conference on Ocean, Offshore & Arctic Engineering; 2019-06-09 - 2019-06-14
OCEAN
- Skjong, Stian; Kyllingstad, Lars Tandle; Reite, Karl Johan; Haugen, Joakim; Ladstein, Jarle; Aarsæther, Karl Gunnar.**
Generic on-board decision support system framework for marine operations. I: ASME 2019 38th International Conference on Ocean, Offshore and Arctic Engineering. Volume 7A: Ocean Engineering. The American Society of Mechanical Engineers (ASME) 2019 ISBN 978-0-7918-5884-4.
OCEAN
- Skulstad, Robert; Li, Guoyuan; Fossen, Thor I.; Vik, Bjørnar; Zhang, Houxiang.**
Dead reckoning of dynamically positioned ships: Using an efficient recurrent neural network. IEEE robotics & automation magazine 2019 ;Volum 26.(3) s.39-51
NTNU

Solaas, Frøydis; Mentzoni, Fredrik; Abrahamsen-Prsic, Mia; Kristiansen, Trygve.
An Experimental and Numerical Study of Added Mass and Damping for Side by Side Plates in Oscillating Flow. ASME 2019 38th International Conference on Ocean, Offshore and Arctic Engineering (OMAE2019); 2019-06-09 - 2019-06-14
OCEAN NTNU

Solaas, Frøydis; Mentzoni, Fredrik; Abrahamsen-Prsic, Mia; Kristiansen, Trygve.
An Experimental and Numerical Study of Added Mass and Damping for Side by Side Plates in Oscillating Flow. I: ASME 2019 38th International Conference on Ocean, Offshore and Arctic Engineering. Volume 7A: Ocean Engineering. ASME Press 2019 ISBN 978-0-7918-5884-4.
OCEAN NTNU

Verma, Amrit Shankar; Gao, Zhen; Jiang, Zhiyu; Ren, Zhengru; Vedvik, Nils Petter.
Structural Safety Assessment of Marine Operations From a Long-Term Perspective: A Case Study of Offshore Wind Turbine Blade Installation. I: ASME 2019 38th International Conference on Ocean, Offshore and Arctic Engineering. Volume 3: Structures, Safety, and Reliability. ASME Press 2019 ISBN 978-0-7918-5878-3.
NTNU UIA

Verma, Amrit Shankar; Jiang, Zhiyu; Ren, Zhengru; Gao, Zhen; Vedvik, Nils Petter.
Response-Based Assessment of Operational Limits for Mating Blades on Monopile-Type Offshore Wind Turbines. Energies 2019;Volum 12.(10)
UIA NTNU

Verma, Amrit Shankar; Jiang, Zhiyu; Vedvik, Nils Petter; Gao, Zhen; Ren, Zhengru.
Impact assessment of a wind turbine blade root during an offshore mating process. Engineering structures 2019 ;Volum 180. s.205-222
UIA NTNU

Verma, Amrit Shankar; Vedvik, Nils Petter; Haselbach, Philipp Ulrich; Gao, Zhen; Jiang, Zhiyu.
Comparison of numerical modelling techniques for impact investigation on a wind turbine blade. Composite structures 2019 ;Volum 209. s.856-878
NTNU UIA

Vieira, Daniel; Oliveira, Felipe; Nishimoto, Kazuo; Rhodes, Donna; Gaspar, Henrique Murilo.
Simulation for construction and operation of offshore salt caves for CO2 storage. VII November Conference - Brazil Norway; 2019-11-11 - 2019-11-13
NTNU

Værnø, Sverre Are Tutturen; Brodtkorb, Astrid H.; Skjetne, Roger.
Compensation of bias loads in dynamic positioning of marine surface vessels. Ocean Engineering 2019; Volum 178. s.484-492
NTNU

Værnø, Sverre Are Tutturen; Skjetne, Roger; Kjerstad, Øivind Kåre; Calabrò, Vincenzo.
Comparison of control design models and observers for dynamic positioning of surface vessels. Control Engineering Practice 2019 ;Volum 85. s.235-245
NTNU UNIS

2020
Cheng, Xu; Li, Guoyuan; Skulstad, Robert; Chen, Shengyong; Hildre, Hans Petter; Zhang, Houxiang.
A Neural Network-Based Sensitivity Analysis Approach for Data-Driven Modeling of Ship Motion. IEEE Journal of Oceanic Engineering 2020 ;Volum 45.(2) s.451-461
NTNU

Fonseca, Icaro Aragao; Gaspar, Henrique Murilo.
Fundamentals Of Digital Twins Applied To A Plastic Toy Boat And A Ship Scale Model. I: Proceedings of the 34th International ECMS - Conference on Modelling and Simulation - ECMS 2020. ECMS European Council for Modelling and Simulation 2020 ISBN 978-3-937436-68-5. s.207-213
NTNU

Gutsch, Martin.
Design for Workability: Scenarios for parametric design optimization. SFI-MOVE Spring Conference 2020; 2020-05-26 - 2020-05-26
OCEAN NTNU

Gutsch, Martin.
Vessel Design Optimization Tool Development Status. SFIMOVE Autumn Conference 2020; 2020-11-25 - 2020-11-25
OCEAN

Gutsch, Martin; Steen, Sverre; Sprenger, Florian.
Operability robustness index as seakeeping performance criterion for offshore vessels. Ocean Engineering 2020 ;Volum 217.
NTNU OCEAN

Han, Xu; Leira, Bernt Johan; Sævik, Svein.
Tuning of vessel seakeeping model parameters based on motion and wave measurements. SFI MOVE Autumn Conference 2020; 2020-11-25 - 2020-11-26
NTNU

Han, Xu; Sævik, Svein; Leira, Bernt Johan.
A Sensitivity Study of Vessel Hydrodynamic Model Parameters. 39th International Conference on Ocean, Offshore & Arctic Engineering; 2020-08-03 - 2020-08-07
NTNU

Han, Xu; Sævik, Svein; Leira, Bernt Johan.
A Sensitivity Study of Vessel Hydrodynamic Model Parameters. I: ASME 2020 39th International Conference on Ocean, Offshore and Arctic Engineering - Volume 1: Offshore Technology. The American Society of Mechanical Engineers (ASME) 2020 ISBN 978-0-7918-8431-7.
NTNU

Jiang, Zhiyu; Yttervik, Rune; Gao, Zhen; Sandvik, Peter Christian.
Design, Modelling and Analysis of a Large Floating Dock for Spar Floating Wind Turbine Installation. Marine Structures 2020 ;Volum 72.
NTNU OCEAN UIA

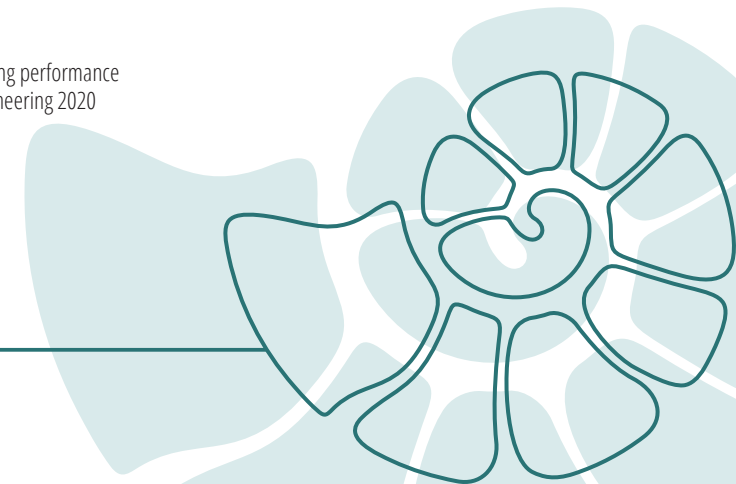

Appendix 3 – List of Publications

Koilo, Viktoriaa.

Energy efficiency and green solutions in sustainable development: evidence from the Norwegian maritime industry. Problems and Perspectives in Management 2020 ;Volum 18.(4) s.289-302
NTNU

Kyllingstad, Lars Tandle; Skjong, Stian.

On-board decision support framework functionality developed in 2020. SFI MOVE Autumn Conference 2020; 2020-11-25 - 2020-11-26
OCEAN NTNU

Larsen, Marie Haugli.

The future of demanding marine operations. SFI-Move autumn conference 2020; 2020-11-25 - 2020-11-26
NTNU

Arnesen, Robert; Andersson, Mathias Dimmen; Ytterland, Sondre.

Maritim cybersikkerhet. NTNU Open 2020 46 s.
NTNU

Li, Guoyuan; Mao, Runze; Hildre, Hans Petter; Zhang, Houxiang.

Visual Attention Assessment for Expert-in-the-loop Training in a Maritime Operation Simulator. IEEE Transactions on Industrial Informatics 2020 ;Volum 16.(1) s.522-531
NTNU

Mentzoni, Fredrik; Kristiansen, Trygve.

Two-dimensional experimental and numerical investigations of parallel perforated plates in oscillating and orbital flows. Applied Ocean Research 2020 ;Volum 97. s.1-20
NTNU

Mentzoni, Fredrik; Kristiansen, Trygve.

Two-dimensional experimental and numerical investigations of perforated plates in oscillating flow, orbital flow and incident waves. Applied Ocean Research 2020 ;Volum 97. s.1-22
NTNU

Moan, Torgeir; Gao, Zhen; Bachynski, Erin Elizabeth; Rasekhi Nejad, Amir.

Recent Advances in Integrated Response Analysis of Floating Wind Turbines in a Reliability Perspective. Journal of Offshore Mechanics and Arctic Engineering 2020 ;Volum 142.(5)
NTNU

Monteiro, Thiago Gabriel; Gaspar, Henrique Murilo; Zhang, Houxiang; Skourup, Charlotte.

A MODEL FOR FORECASTING MENTAL FATIGUE IN MARITIME OPERATIONS. I: Proceedings of the 34th International ECMS - Conference on Modelling and Simulation - ECMS 2020. ECMS European Council for Modelling and Simulation 2020 ISBN 978-3-937436-68-5. s.221-227
NTNU

Monteiro, Thiago Gabriel; Li, Guoyuan; Skourup, Charlotte; Zhang, Houxiang.

Investigating an Integrated Sensor Fusion System for Mental Fatigue Assessment for Demanding Maritime Operations. Sensors 2020 ;Volum 20.(9)
NTNU

Monteiro, Thiago Gabriel; Skourup, Charlotte; Zhang, Houxiang.

Optimizing CNN Hyperparameters for Mental Fatigue Assessment in Demanding Maritime Operations. IEEE Access 2020 ;Volum 8. s.40402-40412
NTNU

Pareliussen, Bjarne.

Digital transitions in the maritime organizations: Changing the Game by Power by the Hour and Remote Monitoring. Nordic Working Life Conference 2020; 2020-09-28 - 2020-09-29
NTNU

Ren, Zhengru; Skjetne, Roger; Jiang, Zhiyu; Gao, Zhen.

Active Single-Blade Installation Using Tugger Line Tension Control and Optimal Control Allocation. International Journal of Offshore and Polar Engineering 2020 ;Volum 30.(2) s.220-227
UIA NTNU

Ren, Zhengru; Zhao, Bo; Nguyen, Dong Trong.

Finite-time Backstepping of a Nonlinear System in Strict-feedback Form: Proved by Bernoulli Inequality. IEEE Access 2020 ;Volum 8. s.47768-47775
NTNU

Skjetne, Roger; Ren, Zhengru.

A survey on modeling and control of thruster-assisted position mooring systems. Marine Structures 2020 ;Volum 74.
NTNU

Skulstad, Robert; Li, Guoyuan; Fossen, Thor I.; Vik, Bjørnar; Zhang, Houxiang.

A Hybrid Approach to Motion Prediction for Ship Docking— Integration of a Neural Network Model into the Ship Dynamic Model. IEEE Transactions on Instrumentation and Measurement 2020 ;Volum 70.
NTNU

Solaas, Frøydis.

Lecture on Hydrodynamic coefficients for subsea structures during installation operations Main findings. SFI-MOVE Spring Conference 2020; 2020-05-26 - 2020-05-26
OCEAN

Solaas, Frøydis; Mentzoni, Fredrik; Abrahamsen-Prsic, Mia; Kristiansen, Trygve.

An Experimental and Numerical Study of Added Mass and Damping for Side-by-Side Plates in Oscillating Flow. Journal of Offshore Mechanics and Arctic Engineering 2020 ;Volum 143.(1)
NTNU OCEAN

Verma, Amrit Shankar; Jiang, Zhiyu; Gao, Zhen; Vedvik, Nils Petter.

Effects of a Passive Tuned Mass Damper on Blade Root Impacts During the Offshore Mating Process. Marine Structures 2020 ;Volum 72.
NTNU UIA

Verma, Amrit Shankar; Jiang, Zhiyu; Ren, Zhengru; Gao, Zhen; Vedvik, Nils Petter.

Effects of Wind-Wave Misalignment on a Wind Turbine Blade Mating Process: Impact Velocities, Blade Root Damages and Structural Safety Assessment. Journal of Marine Science and Application 2020 ;Volum 19. s.218-233
NTNU UIA

Vieira, Daniel; Nishimoto, Kazuo; Ferrari de Oliveira, Felipe; Gaspar, Henrique Murilo.

Simulation Of The Conceptual Design Of Offshore Salt Caves For CO2 Storage. I: Proceedings of the 34th International ECMS - Conference on Modelling and Simulation - ECMS 2020. ECMS European Council for Modelling and Simulation 2020 ISBN 978-3-937436-68-5. s.214-220
NTNU

Vågnes, David; Monteiro, Thiago Gabriel; Halse, Karl Henning; Hildre, Hans Petter.

Low-height lifting system for offshore wind turbine installation: Modelling and hydrodynamic response analysis using the commercial simulation tool SIMA. 39th International Conference on Ocean, Offshore & Arctic Engineering (OMAE 2020); 2020-08-03 - 2020-08-07
NTNU

Wu, Mengning; Stefanakos, Christos; Gao, Zhen.

Multi-step-ahead forecasting of wave conditions based on a physics-based machine learning (PBML) model for marine operations. Journal of Marine Science and Engineering 2020 ;Volum 8.(12) s.1-24
NTNU OCEAN

Xu, Jiafeng; Ataei, Behfar; Halse, Karl Henning; Hildre, Hans Petter; Mikalsen, Egil Tennfjord.

Virtual prototyping of a low-height lifting system for offshore wind turbine installation. 39th International Conference on Ocean, Offshore & Arctic Engineering (OMAE 2020); 2020-08-03 - 2020-08-07
NTNU

2021**Erstad, Erlend; Larsen, Marie Haugli.**

Cyber Security i praksis - Maritim Cyber Risikostyring. Rederikonferansen21; 2021-09-22 - 2021-09-22
NTNU

Han, Xu; Leira, Bernt Johan; Sævik, Svein.

Vessel hydrodynamic model tuning by Discrete Bayesian updating using simulated onboard sensor data. Ocean Engineering 2021 ;Volum 220.
NTNU

Han, Xu; Leira, Bernt Johan; Sævik, Svein; Kaasen, Karl Erik.

Validation of vessel seakeeping model tuning algorithm based on measurements at model scale. Marine Structures 2021 ;Volum 80.
NTNU OCEAN

Han, Xu; Leira, Bernt Johan; Sævik, Svein; Ren, Zhengru.

Onboard tuning of vessel seakeeping model parameters and sea state characteristics. Marine Structures 2021 ;Volum 78.
NTNU

Han, Xu; Ren, Zhengru; Leira, Bernt Johan; Sævik, Svein.

Adaptive identification of lowpass filter cutoff frequency for online vessel model tuning. Ocean Engineering 2021 ;Volum 236.
NTNU

Han, Xu; Sævik, Svein; Leira, Bernt Johan.

Tuning of vessel parameters including sea state dependent roll damping. Ocean Engineering 2021 ;Volum 233.
NTNU

Hong, Sunghun; Vågnes, David; Halse, Karl Henning; Nord, Torodd Skjerve.

Mechanical Coupling Effect on the Horizontal Response of Floating Offshore Wind Turbine Installation Using a Catamaran with a Low Height Lifting System. I: Proceedings of the Thirty-first (2021) International Ocean and Polar Engineering Conference, Rhodes, Greece, June 20 – 25, 2021. International Society of Offshore & Polar Engineers 2021 ISBN 978-1-880653-82-1. s.628-633
NTNU

Koilo, Viktoriia.

Business model development by implementing remote operations. SFI- MOVE spring conference; 2021-05-31
NTNU

Koilo, Viktoriia.

Developing new business models: Logic of network value or cross-industry approach. Problems and Perspectives in Management 2021 ;Volum 19.(2) s.291-307
NTNU

Koilo, Viktoriia.

Evaluation of R&D activities in the maritime industry: Managing sustainability transitions through business model. Problems and Perspectives in Management 2021 ;Volum 19.(3) s.230-246
NTNU

Larsen, Marie Haugli.

Use of Digital Twin Technology in Remote Operations. SFI-Move autumn conference 2021; 2021-11-29 - 2021-11-29
NTNU

Larsen, Marie Haugli; Holmeset, Finn Tore.

The concept of a remote operation center. SFI-Move spring conference 2021; 2021-05-31 - 2021-06-01
NTNU

Larsen, Marie Haugli; Lund, Mass Soldal.

Cyber Risk Perception in the Maritime Domain: A Systematic Literature Review. IEEE Access 2021 ;Volum 9. s.144895-144905 NTNU BI FORSV

Stang, Emilie B.; Vatle, Henrik N.; Utslottøy, Pål.

Cybersikkerhet i maritim industri. Ålesund: NTNU Open 2021 65 s.
NTNU

Mao, Runze; Li, Guoyuan; Hildre, Hans Petter; Zhang, Houxiang.

A Survey of Eye Tracking in Automobile and Aviation Studies: Implications for Eye-Tracking Studies in Marine Operations. IEEE Transactions on Human-Machine Systems 2021 ;Volum 51.(2) s.87-98
NTNU

Pareliussen, Bjarne.

Working across organizations in a dispersed team. SFI-MOVE Spring conference; 2021-05-31 - 2021-06-01
NTNU

Pareliussen, Bjarne; Æsøy, Vilmar; Giskeødegård, Marte Fanneløb.

Professions, work, and digitalization: Technology as means to connective professionalism. Journal of Professions and Organization 2021 s.1-15
NTNU

Appendix 3 – List of Publications

Radhakrishnan, Gowtham.

Digital twins in decision support systems for offshore vessels. SFI MOVE Spring Conference_2021; 2021-05-31 - 2021-06-01
NTNU

Radhakrishnan, Gowtham; Han, Xu; Sævik, Svein; Gao, Zhen; Leira, Bernt Johan.

System Uncertainty Effects on the Wave Frequency Response Of Floating Vessels Based on Polynomial Chaos Expansion. I: ASME 2021 40th International Conference on Ocean, Offshore and Arctic Engineering Volume 2: Structures, Safety, and Reliability. The American Society of Mechanical Engineers (ASME) 2021 ISBN 978-0-7918-8512-3.
NTNU

Ren, Zhengru; Han, Xu; Verma, Amrit Shankar; Dirdal, Johann Alexander; Skjetne, Roger.

Sea state estimation based on vessel motion responses: Improved smoothness and robustness using Bezier surface and L1 optimization. Marine Structures 2021 ;Volum 76.
NTNU

Ren, Zhengru; Skjetne, Roger; Verma, Amrit Shankar; Jiang, Zhiyu; Gao, Zhen; Halse, Karl Henning.

Active heave compensation of floating wind turbine installation using a catamaran construction vessel. Marine Structures 2021 ;Volum 75.
UIA NTNU

Ren, Zhengru; Verma, Amrit Shankar; Ataei, Behfar; Halse, Karl Henning; Hildre, Hans Petter.

Model-free anti-swing control of complex-shaped payload with offshore floating cranes and a large number of lift wires. Ocean Engineering 2021 ;Volum 228.
NTNU OCEAN

Ren, Zhengru; Verma, Amrit Shankar; Li, Ye; Teuwen, Julie J.E.; Jiang, Zhiyu.

Offshore wind turbine operations and maintenance: A state-of-the-art review. Renewable and Sustainable Energy Reviews 2021 ;Volum 144.
UIA NTNU OCEAN

Skulstad, Robert.

Data-Based Modelling of Ships for Motion Prediction and Control Allocation. Ålesund: NTNU 2021 (ISBN 978-82-326-6605-8) 139 s.
NTNU

Skulstad, Robert; Li, Guoyuan; Fossen, Thor I.; Wang, Tongtong; Zhang, Houxiang.

A Co-operative Hybrid Model For Ship Motion Prediction. MIC Journal: Modeling, Identification and Control 2021 ;Volum 42.(1) s.17-26
NTNU

Slåttum, Sindre Sagsveen.

Data-driven sea state estimation for a DP vessel based on distributed inertial measurement units. Norges teknisk-naturvitenskapelige universitet 2021 60 s.
NTNU

Wang, Chunlin; Li, Guoyuan; Skulstad, Robert; Cheng, Xu; Osen, Ottar Laurits; Zhang, Houxiang.

A sensitivity quantification approach to significance analysis of thrusters in dynamic positioning operations.. Ocean Engineering 2021 ;Volum 223.
NTNU

Wu, Mengning; Gao, Zhen.

Methodology for developing a response-based correction factor (alpha-factor) for allowable sea state assessment of marine operations considering weather forecast uncertainty. Marine Structures 2021 ;Volum 79.(103050)
NTNU

Xu, Kun; Larsen, Kjell; Shao, Yanlin; Zhang, Min; Gao, Zhen; Moan, Torgeir.

Design and comparative analysis of alternative mooring systems for floating wind turbines in shallow water with emphasis on ultimate limit state design. Ocean Engineering 2021 ;Volum 219.
NTNU

2022

Abrahamsen-Prsic, Mia; Solaas, Frøydis; Kristiansen, Trygve.

Hydrodynamic Coefficients of Generic Subsea Modules in Forced Oscillation Tests – Importance of Structure Parts. 41st International Conference on Ocean, Offshore and Arctic Engineering; 2022-06-05 - 2022-06-10
NTNU OCEAN

Abrahamsen-Prsic, Mia; Solaas, Frøydis; Kristiansen, Trygve.

Hydrodynamic Coefficients of Generic Subsea Modules in Forced Oscillation Tests – Importance of Structure Parts. I: ASME 2022 41st International Conference on Ocean, Offshore and Arctic Engineering Volume 1: Offshore Technology. The American Society of Mechanical Engineers (ASME) 2022 ISBN 978-0-7918-8585-7.
NTNU OCEAN

Brørby, Bjørn Theodor Torp.

Wave load compensation in DP control systems. Trondheim: NTNU 2022 94 s.
NTNU

Dirdal, Johann Alexander; Skjetne, Roger; Rohá, Jan; Fossen, Thor I.

Online wave direction and wave number estimation from surface vessel motions using distributed inertial measurement arrays and phase-timepath-differences. Ocean Engineering 2022 ;Volum 249.
NTNU

Erstad, Erlend; Larsen, Marie Haugli; Giskeødegård, Marte Fanneløb.

Beredskapsøvelse - Cyber Security. Rederikonferansen22; 2022-05-19 - 2022-05-19
NTNU

Halse, Karl Henning.

SFI MOVE - Project status - Innovative installations of floating wind power systems. SFI MOVE - Spring conference (Project code: 237929); 2022-06-14 - 2022-06-15
NTNU

Haugli-Sandvik, Marie.

Distributed teams in remote operations - Communication and situational awareness. SFI-Move autumn conference 2022; 2022-11-29 - 2022-11-29
NTNU

Haugli-Sandvik, Marie.

Maritim cybersikkerhet. GATS; 2022-09-06 - 2022-09-06
NTNU

Haugli-Sandvik, Marie.

Remote Operation Centers - Concepts and experiences. SFI-Move autumn conference 2022; 2022-11-29 - 2022-11-29
NTNU

Gjerde, Magnus; Sørum, Andreas; Kvam, Andreas Mulelid.

Digitalisering knyttet til sikker drift og cybersikkerhet på fartøy. Ålesund: NTNU Open 2022 73 s.
NTNU

Hong, Sunghun; Zhang, Houxiang; Nord, Torodd Skjerve; Halse, Karl Henning.

Effect of fender system on the dynamic response of onsite installation of floating offshore wind turbines. Ocean Engineering 2022 ;Volum 259.
NTNU

Jagite, George.

Forecasting the short-term wave-induced motions and loads on a floating DP installation vessel for lifting applications. SFI MOVE Conference; 2022-06-01 - 2022-06-01
OCEAN

Jagite, George.

On the deterministic prediction of waves using real X-Band radar measurements. SFI MOVE Conference; 2022-11-01 - 2022-11-01
OCEAN

Koilo, Viktoriaa.

A framework for cost-benefit analysis of business model within maritime remote operations. SFI- MOVE autumn conference; 2022-06-14 - 2022- 06-15
NTNU

Koilo, Viktoriaa.

Business model for integrated sustainable value creation: A supply chain perspective. Problems and Perspectives in Management 2022 ;Volum 20.(1) s.93-107
NTNU

Koilo, Viktoriaa.

Innovation policy: a path towards competitiveness and economic growth in the maritime industry. Fjordkonferansen-2022, NYSKAPING; 2022-06-16 - 2022-06-17
NTNU

Koilo, Viktoriaa; Grytten, Ola Honningdal; Emblemsvåg, Jan.

The interplay between technological innovation, energy efficiency, and economic growth: Evidence from 30 European countries. Problems and Perspectives in Management 2022 ;Volum 20.(3) s.448-464
NHH NTNU

Kyllingstad, Lars Tandle.

A framework for maritime decision support systems. Subsea Lifting Operations Conference 2022; 2022-12-06
OCEAN

Kyllingstad, Lars Tandle.

An architecture for on-board decision support systems. SFI MOVE 2022 spring conference: Workshop on on-board decision support and subsea lifting operations; 2022-06-15
OCEAN

Larsen, Marie Haugli; Erstad, Erlend.

Maritime cyber security training and awareness. SFI-Move spring conference 2022; 2022-06-14 - 2022-06-15
NTNU

Larsen, Marie Haugli; Lund, Mass Soldal; Bjørneseth, Frøy Birte.

A model of factors influencing deck officers' cyber risk perception in offshore operations. Maritime Transport Research 2022 ;Volum 3.
HINN NTNU

Larsen, Marie Haugli; Pareliussen, Bjarne.

Remote operations and digital twins - A conceptual approach to new ways of collaboration between ship and shore. Fjordkonferansen 2022; 2022-06-16 - 2022-06-17
NTNU

Larsen, Marie Haugli; Pareliussen, Bjarne; Bjørneseth, Frøy Birte.

Experiences from testing of our Remote Operation Center. SFI-Move spring conference 2022; 2022-06-14 - 2022-06-15
NTNU

Liu, Ting.

Installation of OWT with alternative vessel concept. SFI MOVE Spring conference; 2022-06-14 - 2022-06-15
NTNU

Marley, Mathias; Skjetne, Roger.

Mitigating Force Oscillations in a Wave Energy Converter Using Control Barrier Functions. I: ASME 2022 41st International Conference on Ocean, Offshore and Arctic Engineering Volume 8: Ocean Renewable Energy. The American Society of Mechanical Engineers (ASME) 2022 ISBN 978-0-7918-8593-2.
NTNU

Moreau, Mael Korentin Ivan; Kristiansen, Trygve; Ommani, Babak; Molin, Bernard Jean Marie.

An upright bottomless vertical cylinder with baffles floating in waves. Applied Ocean Research 2022 ;Volum 119.
NTNU OCEAN

Radhakrishnan, Gowtham.

Model tuning and long-range response prediction. SFI-MOVE Spring 2022 conference; 2022-06-14 - 2022-06-15
NTNU

Radhakrishnan, Gowtham; Leira, Bernt Johan; Gao, Zhen; Sævik, Svein; Gomola, Alojz.

Motion response prediction of marine vessels based on hydrodynamic models updated through on-site measurements. I: ASME 2022 41st International Conference on Ocean, Offshore and Arctic Engineering. Volume 2: Structures, Safety, and Reliability. The American Society of Mechanical Engineers (ASME) 2022 ISBN 978-0-7918-8586-4.
NTNU

Ravnestad, Elias Strømmen.

Time-domain wave estimation and prediction using wave radar on R/V Gunnerus. Trondheim: NTNU 2022 83 s.
NTNU

Appendix 3 – List of Publications

Ren, Zhengru; Han, Xu; Yu, Xingji; Skjetne, Roger; Leira, Bernt Johan; Sævik, Svein; Zhu, Man.

Data-driven simultaneous identification of the 6DOF dynamic model and wave load for a ship in waves. Mechanical systems and signal processing 2022 ;Volum 184. s.1-16
NTNU

Skulstad, Robert.

Hybrid modelling for ship motion prediction. SFI MOVE summer conference; 2022-06-14 - 2022-11-14
NTNU

Wang, Chunlin; Wang, Tongtong; Nord, Torodd Skjerve; Zhang, Houxiang; Li, Guoyuan; Osen, Ottar.

Uncertainty and sensitivity analysis for the performance evaluation of ship dynamical model. I: Proceedings of The Thirty-second (2022) International OCEAN AND POLAR ENGINEERING CONFERENCE ISOPE-2022 Shanghai, China (Hybrid) June 5–10, 2022. 2022 ISBN 978-1-880653-81-4. s.2309-2314
NTNU

Wu, Mengning; Gao, Zhen; Zhao, Yuna.

Assessment of allowable sea states for offshore wind turbine blade installation using time-domain numerical models and considering weather forecast uncertainty. Ocean Engineering 2022 ;Volum 260.
NTNU

Yuan, Shuai.

FMI-based Co-simulation of Low-height Lifting System for Offshore Wind Turbine Installation. SFI MOVE spring conference; 2022-06-14 - 2022-06-15
NTNU

Yuan, Shuai; Ataei, Behfar; Halse, Karl Henning; Zhang, Houxiang; Hildre, Hans Petter.

FMI-Based Co-Simulation of Low-Height Lifting System for Offshore Wind Turbine Installation. I: ASME 2022 41st International Conference on Ocean, Offshore and Arctic Engineering Volume 8: Ocean Renewable Energy. The American Society of Mechanical Engineers (ASME) 2022 ISBN 978-0-7918-8593-2.
NTNU

Zhao, Shujie; Meng, Xun; Gao, Zhen; Li, Huajun.

Numerical modeling of nonstationary hydrodynamic forces and induced motions of a coupled offshore floating installation system. Ocean Engineering 2022 ;Volum 246.
NTNU

Zhou, Hongyu; Ren, Zhengru; Marley, Mathias; Skjetne, Roger.

A Guidance and Maneuvering Control System Design With Anti-Collision Using Stream Functions With Vortex Flows for Autonomous Marine Vessels. IEEE Transactions on Control Systems Technology 2022 ;Volum 30.(6) s.2630-2645
NTNU

2023

Dirdal, Johann Alexander; Skjetne, Roger; Rohá, Jan; Fossen, Thor I.

A phase-time-path-difference approach for online wave direction and wave number estimation from measured ship motions in zero and forward speed using a single inertial measurement unit. Ocean Engineering 2023 ;Volum 288.
NTNU

Erstad, Erlend; Haugli-Sandvik, Marie.

Maritim cyber breakfast seminar. Maritim cyber breakfast seminar; 2023-02-16 - 2023-02-16
NTNU

Erstad, Erlend; Haugli-Sandvik, Marie.

Maritim cyber sikkerhet seminar - Fokus på operasjoner og opplæring. Maritim cyber sikkerhet seminar - Fokus på operasjoner og opplæring; 2023-03-28 - 2023-03-29
NTNU

Erstad, Erlend; Haugli-Sandvik, Marie.

Maritime cyber security workshop. Maritime cyber security workshop; 2023-02-16 - 2023-02-16
NTNU

Haugli-Sandvik, Marie.

Remote operations and dispersed teams. SFI-Move final conference; 2023-05-30 - 2023-05-31
NTNU

Haugli-Sandvik, Marie; Erstad, Erlend.

Maritim Cybersikkerhet - Hvordan forholde seg?. Haramskonferansen; 2023-02-14 - 2023-02-14
NTNU

Haugli-Sandvik, Marie; Pareliussen, Bjarne; Bjørneseth, Frøy Birte.

Kommunikasjon og distribuert situasjonsbevissthet i maritime fjernoperasjoner. I: Nyskaping : Fjordantologien 2023. Universitetsforlaget 2023 ISBN 978-82-15-06937-1. s.269-285
NTNU

Hygen, Jan-Erik.

Deterministic Response Prediction of Wave-induced Vessel Motions. Trondheim: NTNU 2023 103 s.
NTNU

Kyllingstad, Lars Tandle; Skjong, Stian; Ladstein, Jarle; Haugen, Joakim.

AMADEA - Adaptable Maritime Decision Support Architecture. SINTEF akademisk forlag 2023
NTNU OCEAN

Mo, Harald; Kongshaug, Marie Fejerskov.

Real-time compensation of residual loads in dynamic positioning control systems. Trondheim: NTNU 2023 129 s.
NTNU

Nickpasand, Mehrnoosh; Gaspar, Henrique Murilo.

Digital twin for agile manufacturing: challenges from the offshore wind turbine industry. Proceedings - European Council for Modelling and Simulation (ECMS) 2023 ;Volum 37.
NTNU

Nickpasand, Mehrnoosh; Gaspar, Henrique Murilo.

Ilities for Responsive Manufacturing: A Case from Offshore Wind Turbine Manufacturing. I: Proceedings of 2023 18th System of Systems Engineering Conference (SoSE 2023); 14-16 June 2023, Lille, France. IEEE conference proceedings 2023 ISBN 979-8-3503-2723-6.
NTNU

Radhakrishnan, Gowtham; Han, Xu; Leira, Bernt Johan; Gao, Zhen; Sævik, Svein.

Calibration of high-fidelity hydrodynamic models utilizing on-site vessel response measurements. Ocean Engineering 2023 ;Volum 278.
NTNU

**Radhakrishnan, Gowtham;
Leira, Bernt Johan; Gao, Zhen; Sævik, Svein;
Christakos, Konstantinos.**

Retrieval of Ocean Wave Spectra From X-Band Marine Radar Images Using Inversion Schemes Based on Auto-Spectral Analysis. I: ASME 2023 42nd International Conference on Ocean, Offshore and Arctic Engineering : Volume 5 : Ocean Engineering. The American Society of Mechanical Engineers (ASME) 2023 ISBN 978-0-7918-8687-8.
NTNU

**Radhakrishnan, Gowtham; Leira, Bernt Johan;
Gao, Zhen; Sævik, Svein; Han, Xu.**

Analyzing the Sensitivity of Wave Frequency Responses of Floating Vessels to Uncertain System Variables Utilizing Polynomial Chaos Expansion. Journal of Offshore Mechanics and Arctic Engineering 2023 ;Volum 146.(3)
NTNU

**Radhakrishnan, Gowtham; Leira, Bernt Johan;
Gao, Zhen; Sævik, Svein; Kaasen, Karl Erik;
Christakos, Konstantinos; Dirdal, Johann
Alexander.**

A Methodology for Tuning of Computational Vessel Models Utilizing Wave Measurements From X-Band Marine Radar and Wave Buoy. I: ASME 2023 42nd International Conference on Ocean, Offshore and Arctic Engineering : Volume 5 : Ocean Engineering. The American Society of Mechanical Engineers (ASME) 2023 ISBN 978-0-7918-8687-8.
MET NTNU OCEAN

Sanchez Martin, Luis Fernando.

Online Digital Twin and a Decision Support for Safe Maneuvering of R/V Gunnerus. Trondheim: NTNU 2023 110 s.
NTNU

**Skulstad, Robert; Li, Guoyuan; Fossen, Thor I.;
Zhang, Houxiang.**

Constrained control allocation for dynamic ship positioning using deep neural network. Ocean Engineering 2023 ;Volum 279.
NTNU

**Tvergrov, Eli Anne; Haugli-Sandvik, Marie;
Erstad, Erlend.**

Kva gjer du om nokon tek kontroll over skipet ditt?. Gemini 2023
NTNU

**Tvergrov, Eli Anne; Haugli-Sandvik, Marie;
Erstad, Erlend.**

What do you do if a hacker takes over your ship?. Norwegian SciTech News 2023
NTNU

**Vieira, Daniel Prata; Fonseca, Icaro Aragao;
Nishimoto, Kazuo; Assi, Gustavo; Gaspar,
Henrique Murilo; Rhodes, Donna.**

Leveraging epoch-era analysis and digital twin for effective system concept and execution: A CO2 storage salt-cave project. Systems Engineering 2023
NTNU



